



## Numerical Analysis of the Effect of Train Speed and Axle Load on Rail Fastening System Components for Heavy Haul Track

Ntakiyemungu Mathieu<sup>1</sup>, Elias Kassa<sup>2\*</sup>, Abrham Gebre<sup>3</sup>

<sup>1,3</sup>Civil Infrastructure Program, African Railway Center of Excellence, Addis Ababa University, Addis Ababa, Ethiopia

<sup>2</sup>Civil and Transport Engineering Department, Norwegian University of Science and Technology, Trondheim, Norway

### ARTICLE INFO

#### Article history:

Received: 11.05.2019

Accepted: 19.07.2019

Published: 24.12.2019

#### Keywords:

Deformation

Fastening system

Speed

Axle load

ANSYS

Mechanical design

### ABSTRACT

With the ever-increasing demand for heavy haul and high speed trains the track, especially fastening system, suffers a lot and is experiencing unexplainable failures which reduce the life of the entire track. Although the numerous researches have been conducted on fastening system for different reasons (many concentrated on one component), few researches have been conducted on effect of train speed and axle load on all components of the fastening systems. In this research an ANSYS Software is used to numerically analyze the effect of speed and axle load for heavy haul on fastening system components. Different speeds and axle loads are considered. It is shown that by increasing the ratio of the lateral to vertical load (L/V ratio) the deformation increases at high rate compared with the increments in the speed. The results show that when this ratio increases from 0.1 to 0.5, by considering the speed of 100 km/h for 25t axle load, the rail deformation increases 299.5%, railpad 115.5%, abrasion plate 69.1%, rail clip 162.1%, bolt 117.4 %, shoulder 223.8% and top of the sleeper 55.1 %. It is also shown that by increasing the speed from 80km/h to 160km/h the deformations, in all fastening system components, increase to an average of 32%. Increase of axle load from 25t to 40t causes the deformations to increase up to 13% compared to the increase of speed. It means that the increase of axle load is more effective compared with the increasing speed. The results are expected to add on more understanding of the mechanical behavior of fastening systems when subjected to different loading scenarios.

## 1. Introduction

The fastening system is an important component as it facilitates to transfer load and holds the rail to the sleeper and to the substructure. There is an increase of railway traffic and challenging service environments that is experienced worldwide. The failures of fastening systems have been growing unexplainably and causing a reduction of the service life of the fastening system itself and the track in general on other hand. Numerous researches have been conducted on fastening

systems components [1-5]. However further research are needed in order to fully understand the causes and failure of rail fastening systems, because it has an effect on performance of track parameters such as track gauge, rail seat inclination, track vertical stiffness, and electrical insulation [6].

Due to increase of annual tonnage, concrete sleepers and fastening systems have been experiencing a wide variety of failures that include rail seat deterioration, insulator wear, shoulder deterioration, and worn rail pads [1].

\*Corresponding author, Professor  
Email: elias.kassa@ntnu.no

Researches have been focusing on investigating the performance of different fastening systems under laboratory and field loading environments, but the behavior of concrete sleeper fastening systems under different loading conditions is not fully understood.

Numerous researches have been conducted on fastening systems for different reason and it has been shown that the defects on rail and sleeper-fastening systems are the main causes of derailment [7]. Other research has been done in order to further understand the mechanical behavior of fastening system. Holder et al [8] conducted a laboratory research to investigate the lateral performance of Skl-style fastening system. The purpose was to characterize the lateral load path in fastening system by using the Lateral Load Evaluation (LLED) technology. Williams et al [9] conducted a research to quantify the demands on the insulator through analysis of the transfer of lateral wheel loads into the fastening system by measuring the magnitude of lateral forces entering the shoulder, but no conclusion drawn as the threshold of the forces resisted by the shoulder or other components as a results of the vertical load and lateral loads increase. Orguei et al [10] used the dynamical mechanical analysis method to measure the dynamic behavior of rail pad under a wide range frequency but there is still need to know the influence of speed on the displacement of railpad. On the other Van Dyk et al [11] studied the mechanical design of concrete sleepers and elastic fastening systems under current loading in order to improve the understanding of mechanical behavior of the concrete sleeper-fastening system, later provide the basis of mechanical design process. Wen et al [12] reported on the contact-impact stress analysis of rail joint region using the dynamic finite element method. Furthermore, Williams et al [9] conducted an experimental field investigation on quantifying the distribution of lateral forces by use of the Lateral Load Evaluation Device (LLED). Additionally, Sadeghi et al [13] conducted a research aiming to investigate the impact of loading conditions (including train speed and train axle load) on clips fatigue. After conducting various tests they concluded that axle loads are more effective in causing considerable deformations on rail clip than the train speed. From the above investigation they considered few factors that can cause clip deformation and they didn't show

how much axle load can cause the failure of the clip based on mechanical properties of the clip.

Although the numerous researches have been conducted on fastening system for different reasons (many concentrated on one component), very few research have carried out to look onto the effect of train speed and axle load on all component of the fastening systems. Considering that there is an increase of axle load and speed which comes with unexplainable failures of fastening system component, so a study is needed to look at the influence of speed not only on one component but in all components of fastening systems as a whole.

One type of research that needs to be conducted is to investigate the mechanical behavior of the fastening system due to increase of axle load and speed. It is known that the speed increase causes high increase of dynamic forces which will ultimately cause the failure of the track. One of the affected components will be the fastening components. The aim of this research is to analyze the effect of axle load and speed for heavy haul on fastening system components to further understand the mechanical behavior of fastening system components. The outcome will lead to design the track components based on the concepts of the mechanical design.

## **2. Methodology**

This numerical analysis was conducted on widely used fastening system (Vossloh system) as shown in Figure 1. All components are modelled as solids, mainly for simplifying. Some components are considered as spring-damper in model by ignoring the longitudinal and lateral dimensions of the components and considering only the vertical direction. This may have an impact on reproduction of vertical track dynamics [14]. Another advantage of modelling the components by using solid elements is to have the same degrees of freedom as suggested by Prakoso [15]. In this analysis, the effect of axle load increase was investigated and speed as well as the axle load were varied in order to have more insight on the influence of both speed and axle load. This will help to capture the relationship of this variation and the effect it has on deteriorating the fastening components.

In this research the ANSYS software version 16 is used to numerically analyze the model in question.

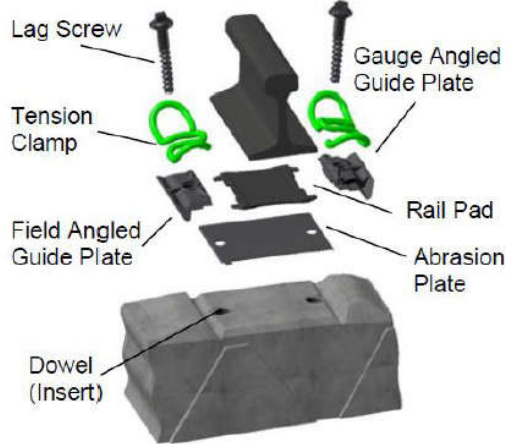

Figure 1. Vossloh Fastening Systems, Inc. W 40 [11]

The ANSYS software uses finite element method in analysis and was used by many researchers in analyzing the track structures [15-21]. The transient analysis is performed in ANSYS Workbench to analyze the dynamic behavior of the model. The author uses the workbench as it is easy to manipulate the model than APDL. The analysis is focusing on the effect of the speed on the fastening system. The speed in Table 1 is chosen in the analysis, the choice is based on the values that most of the heavy hauls use worldwide.

Table 1. Vertical load for different speeds

Speed (km/h)	Dyna mic factor	Rail seat load (kN)			
		Axle load (t)			
		25t	30t	35t	40t
80	1.482	94.47	113.5	132.2	151.2
100	1.603	102.2	122.6	143.0	160.3
120	1.723	109.8	131.8	153.7	172.3
160	1.964	125.3	150.2	175.3	196.4

The dimensions of different components used in this analysis are summarized in Table 2. The material properties from the literature [17], are used as the initial starting point, and are summarized in Tables 3&4.

Table 2. Components dimensions (USA HHS 36/6 RAIL ONE GmbH 2014)

Parameters	Unit
Concrete grade	C 50/60
Sleeper length (L)	2600 mm
Sleeper width (W)	272 mm
Sleeper height (H)	252 mm
Height of centre of rail base	248 mm
Height of sleeper centre ( $h_s$ )	190 mm
Rail dimensions	UIC60
Railpad dimensions	150x160x6 mm
Abrasion plate dimensions	150x170x7 mm
Insulator dimensions	160x45x26 mm
Rail clip diameter	16mm
Bolt diameter	24mm

In case of high speed railway fastening system W42 (Figure 1) is used as it can be used where speed is higher than 250km/h with axle load less than 30t. The speeds of 80, 100, 120 and 160 km/h are considered. These speeds are chosen because most of the heavy haul lines are designed not to exceed a speed of 160km/h. The diameter of wheel is taken as 864mm, the common size used in heavy hauls. The different wheel load with different axle load and rail seat loads used are calculated based on the Equations (1-5) from AREA quoted by Doyle [23] to account for the dynamic factor as the speed increases, as it is indicated in Table 1.

$$\phi = 1 + 5.21 \frac{V}{D} \quad (1)$$

$$P = \frac{\text{Axle load}}{2} \times \phi \quad (2)$$

$$q_r = DF \times P \quad (3)$$

$$K_1 = \frac{2(l_e - l_b) \times \tan \alpha_1}{\ln \left[ \left( \frac{l_e}{l_b} \right) \left( \frac{l_b + 2h_1 \tan \alpha_1}{l_e + 2h_1 \tan \alpha_1} \right) \right]} \times E_1 \quad (4)$$

$$K_2 = \frac{2(l_e - l_b) \times \tan \alpha_2}{\ln \left[ \left( \frac{l_b + 2h_1 \tan \alpha_1}{l_e + 2h_1 \tan \alpha_1} \right) \left( \frac{l_b + 2h_1 \tan \alpha_1 + 2h_2 \tan \alpha_2}{l_e + 2h_1 \tan \alpha_1 + 2h_2 \tan \alpha_2} \right) \right]} \times E_2 \quad (5)$$

$$\frac{1}{K} = \frac{1}{K_1} + \frac{1}{K_2}$$

Table 3. Material properties of the model components [22]

Component	Young's Modulus (GPa)	Poisson's Ratio	Yielding Strength (MPa)	Ultimate/Peak Strength (MPa)	Density (kg/m <sup>3</sup> )	Cracking Strength (MPa)
Concrete	30.0	0.2	NA	48.3	2400	55
Clip	158.6	0.29	1261.8	1393.2	1800	
Rail	210	0.3	1034.3	1034.3	7850	
Rail pad	0.1	0.49	8.3	35.9	980	
Abrasion	3.0	0.39	64.1	84.8	7800	
Bolt	206.84	0.3	640	800	7800	
Insulator	3.0	0.39	64.1	84.8	7800	

Table 4. Other properties [17]

Element	Parameter	Value	Unit
Rail	$\rho$	7.85	ton / m <sup>3</sup>
	$E$	210×10 <sup>6</sup>	kN / m <sup>2</sup>
	$\nu$	0.30	-
Sleeper	$k_p$	100×10 <sup>3</sup>	kN / m
	$m$	0.15	ton
Ballast	$k_b$	34×10 <sup>3</sup>	kN / m
	$c_b$	12.30	kNs / m

Where P is the design load in kN

Where V is speed (km/h)

$\phi$  is the dynamic factor

D is wheel diameter (mm) =864mm

$q_r$  is rail seat load

DF is a distribution factor, expressed as a percentage of the wheel load and for concrete sleepers is obtained as 51%

$L_e$  and  $L_b$  are the effective support lengths of half sleeper, and the sleeper width, respectively. Also,  $h_1$ ,  $h_2$  are the thickness of the ballast and sub-ballast layers, respectively.  $E_1$  and  $E_2$  are the elastic moduli for the ballast and sub-ballast layers, respectively.  $K$ ,  $K_1$  and  $K_2$  combined

stiffness for ballast and sub-ballast, stiffness for ballast and stiffness for sub-ballast, respectively.

In order to simulate the component interaction and friction between them, the coefficients of friction are defined. The COFs are defined from literature [24-26]. They are summarized in the Table.5.

In railways there is an ever increasing demand for higher axle loads. In order to capture the effect of axle load increment, the axle loads of 25, 30, 35, and 40t are chosen. They are chosen based on most used worldwide and future considerations, especially the 40t axle load. In the analysis a combination of lateral and vertical load was used with ratio of 0.1, 0.3 and 0.5 (lateral load to vertical load) by keeping the vertical load constant.

Table 5. COFs defined in the FE model [22]

Component Name	Frictional Interaction	COF values
Pad	Pad-Rail	0.3
	Pad-Abrasion plate	0.3
Abrasion frame	Plate-concrete	0.3
Rail clip	Clip-rail-insulator	0.3
Insulator	Insulator-concrete-clip	0.3
Bolt	Bolt-concrete	0.3

The other ratio can be interpolated. The ratio is limited to 0.5 because it is believed that it's the worst case that may happen. The wheel load and lateral load are applied in the middle of rail on single sleeper (Figures 2&3) and on two sleepers (Figure 4). The bolt torque moment is represented by bolt preload taken as 10kN per bolt as per Chinese standards [27].

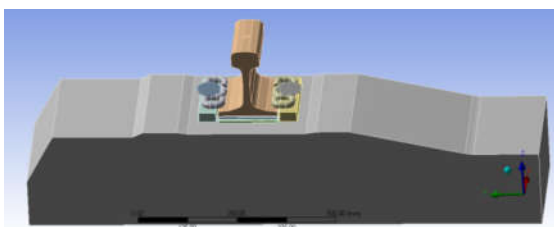

Figure 3. The model of a single sleeper

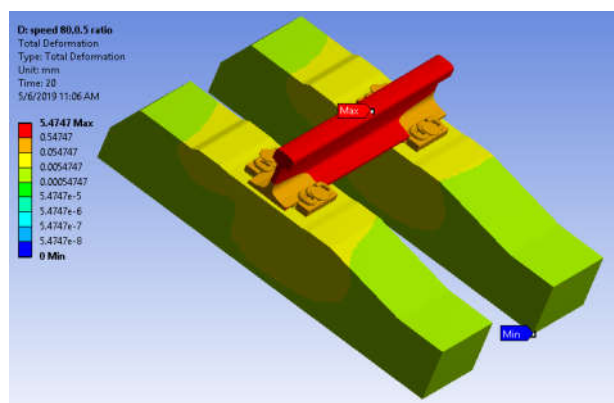

Figure 4. Equivalent Von Mises stresses with a speed of 100 km/h, rail resting on two sleepers

The model consists of rail, rail pad, abrasion plate, rail clip, bolt, shoulder and sleeper which are modeled as solid to account for the real situation on ground. Their dimensions are summarized in Table 2. A space of 5mm was left between shoulder and rail. This was done to let the shoulder move laterally freely so that it cannot touch the rail during the lateral displacement. Since the focus is on superstructure, the bottom of the sleeper is fixed in all directions for simplifications. The boundary conditions are set up. All components are set free in all directions and the ballast material is considered as viscoelastic springs where spring stiffness  $K$  is obtained by using the Equations (4&5) [28]. The damping coefficient is obtained from the literature as indicated in Table 4.

### 3. Results and Discussions

During the numerical analysis the displacements on different fastening system and at the top of the sleeper are captured. In the analysis a combination of vertical and lateral load, by keeping vertical load constant and varying the lateral load for different  $L/V$  ratios of 0.1, 0.3 and 0.5 are considered. Other ratios maybe interpolated. Figures 5 to 7 present the deformations of fastening system components subjected to different axle loads.

In the analysis, the vertical load is kept constant, only the lateral load is varied to the ratio of 0.1, 0.3 and 0.5. The ratios are chosen randomly, by expecting that in the worse cases it can reach the half of the vertical load. The other ratios will be interpolated. From the above charts (Figures 5-7) it is seen that as the speed increases, the deformation also increases to higher values.

As it is expected, the rail has high deformation compared to other components. The railpad is the one that has a high rate of increase among the fastening components, this may be due to its softness. Among the others, the rail clip also has high deformation; this is due to the clip force that is applied on it. The imparted load from lateral and vertical loads together with torque load contributed to that increase.

By increasing the  $L/V$  ratio, the deformation also increases, this shows that the lateral force plays an important role in deteriorating the fastening systems, because the vertical load was

kept constant. From the results, it is also seen that the fastening systems that is on the opposite side where the lateral force is applied, suffers a lot more than the other side. This means that one side of the fastening system deforms on a higher rate than the other depending where the lateral force is applied. The fastening component on the curve has to be designed differently with that of

the tangent track, because it is where the lateral load is higher

Increasing the speed from 80 km/h to 160 km/h on the ratio of 0.5 for 25 t of axle load; the deformation on rail increases 32.49 %, railpad increases 31.89 %, abrasion plate increases 32.23%, the rail clip increases 32.33%, the bolt

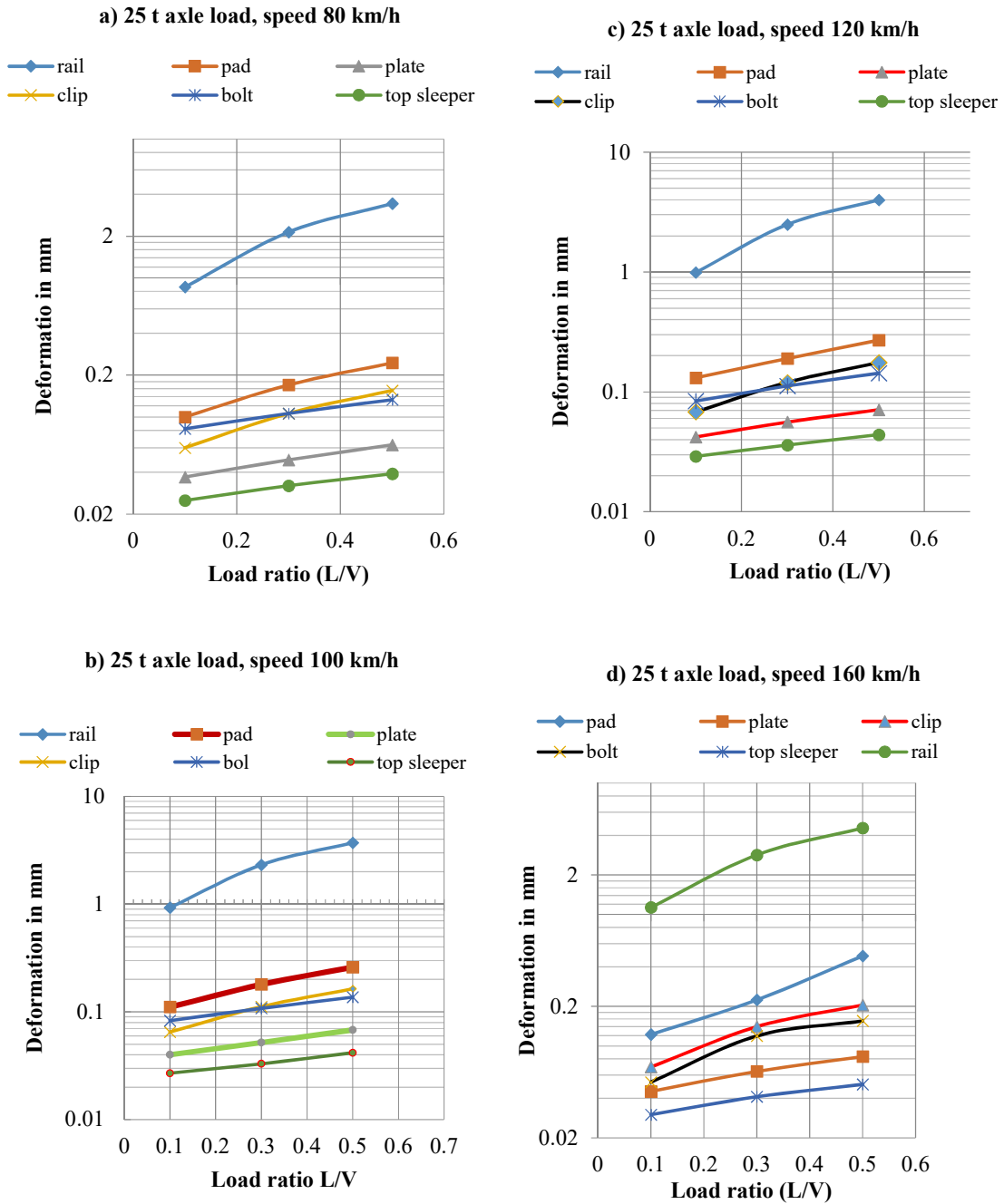

Figure 5(a-d). Deformations of fastening component for 25t axle load with different speed

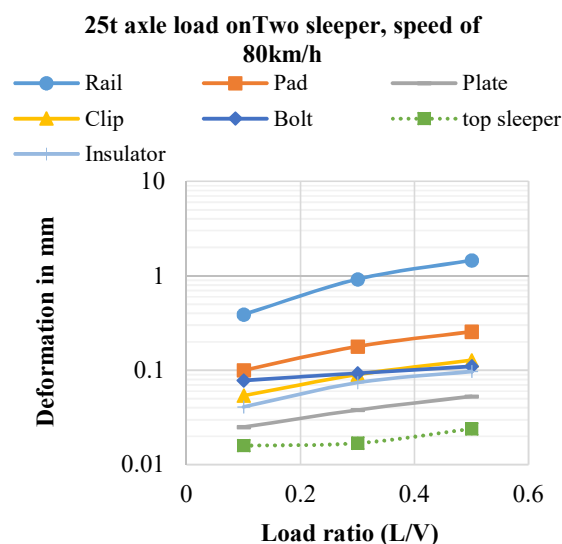

Figure 6. Deformation of different fastening component with rail resting on two sleepers

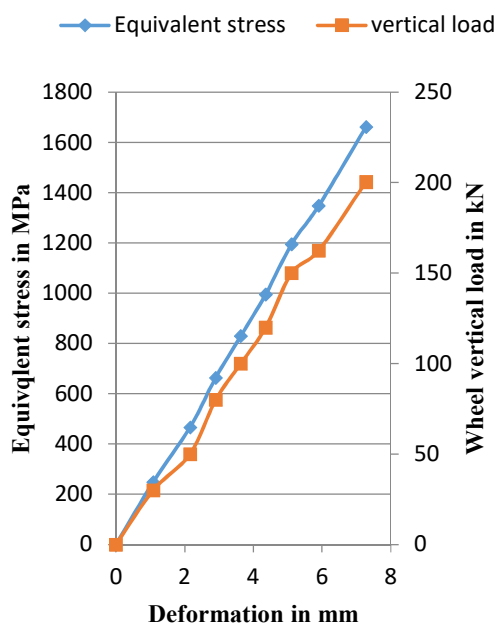

Figure 7. Load-stress-deformations for a speed of 100km/h

increases 23 %, shoulder increases 32.7 % and top sleeper deformation increases 31.7 %. From this percentage of increment, it is seen that most of the components endure increase by almost 32 %. With these results it can be concluded that almost all fastening systems' components deform to the same percentages. That means the fastening system should be designed in accordance with the applied load and speed.

On the other hand, when the lateral to vertical load ratio increases from 0.1 to 0.5, for example considering the speed of 100 km/h for 25t axle load, the rail deformation increases 299.5%, railpad 115.5%, abrasion plate 69.1%, rail clip 162.1%, bolt 117.4 %, shoulder 223.8% and top sleeper 55.1 %. With these percentages, it is observed that by increasing the L/V ratio the deformation increases at a higher rate compared with the increment of speed. The results show that the increase of lateral force has a greater effect than increasing the speed. It means, during the construction, one has to limit the high increase of lateral force by increasing the lateral resistance. Some of the measures to increase the lateral resistance are: using friction sleeper, widening the curve, use of under sleeper pads, reducing the sleeper spacing and constraining the sleepers.

Considering the load applied in the middle of the rail that is supported by two sleepers Figure 4, there is not much change on the deformation, but it slightly decreases on the rail and slightly increases on the other components as expected because the applied load is a little bit away from where the fastening components are. This is in line with what other research have found. Powrie and Pen [29] in their book quoted where he found that when the load is applied in mid-span, there is usually no significant additional increment of deflection on the rail relative to adjacent sleeper supports.

By increasing the speed it is shown that the deformation also increases. The speed has more influence in deteriorating the fastening system, and they get deteriorated at high rate as the axle load increases. Figure 8(a-e) shows the increase of deformation by increasing the axle load for different speeds on L/V ratio of 0.5. The ratio of 0.5 is chosen by believing that the worst scenario can happen on this case.

From the results, taking an example of deformation of railpad for 40t of axle load on speed of 100 km/h with a L/V ratio of 0.5; it is increased up to 59.6% compared to the deformation for 25t axle load with same speed and ratio. When comparing with the increase of speed from 80 to 160 km/h for the same material on the ratio of 0.5 the percentage increase is 49.2%. It shows an increase of almost 10%.

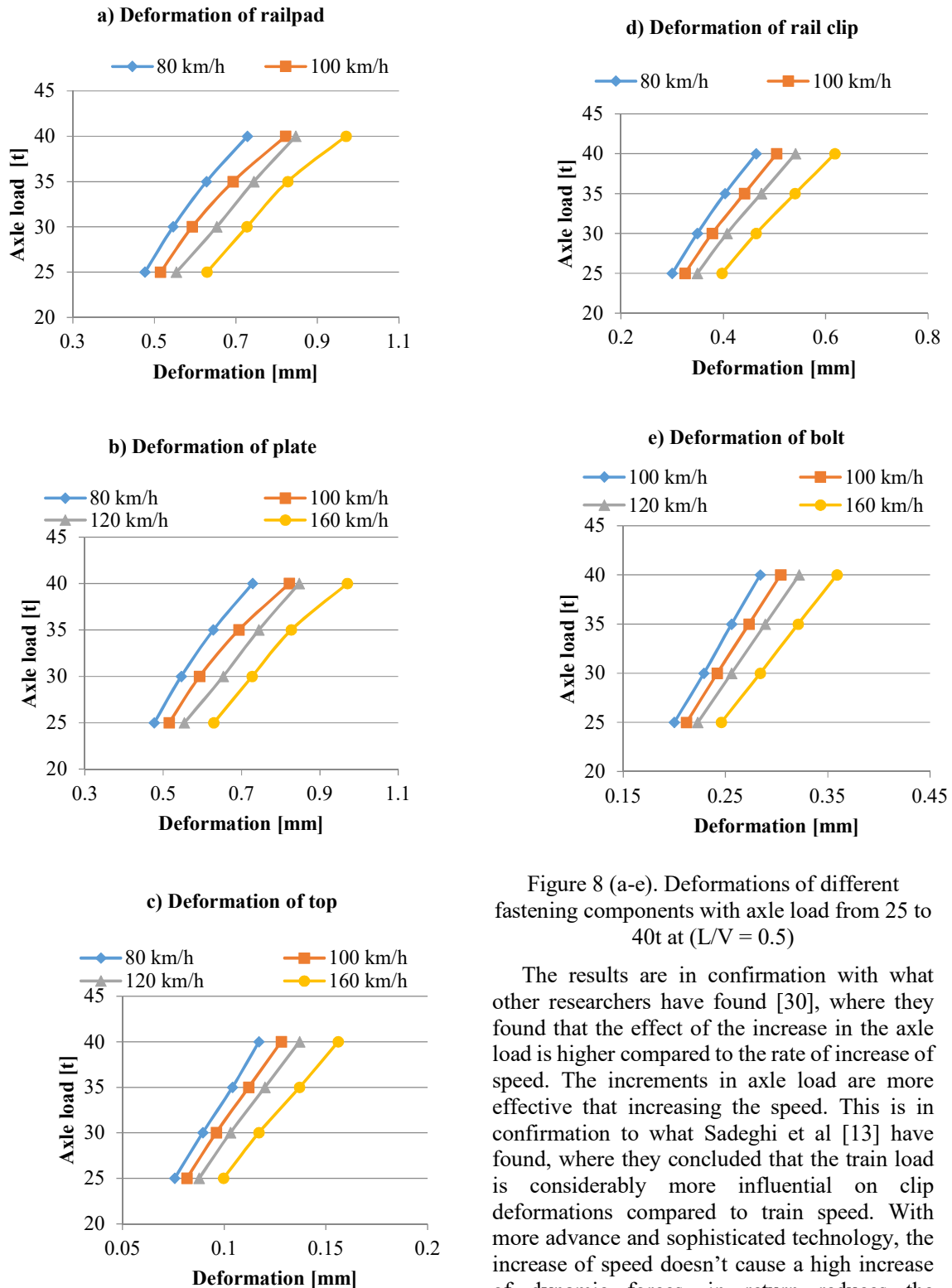

Figure 8 (a-e). Deformations of different fastening components with axle load from 25 to 40t at (L/V = 0.5)

The results are in confirmation with what other researchers have found [30], where they found that the effect of the increase in the axle load is higher compared to the rate of increase of speed. The increments in axle load are more effective than increasing the speed. This is in confirmation to what Sadeghi et al [13] have found, where they concluded that the train load is considerably more influential on clip deformations compared to train speed. With more advanced and sophisticated technology, the increase of speed doesn't cause a high increase of dynamic forces, in return reduces the deformations on different track components. It is expected to have higher dynamic forces when the defects are increased. The results of fastening system components when axle load increases from 25t to 40t are summarized in Figure 8(a-e).



#### 4. Conclusions and Recommendations

The numerical analysis is performed to capture the effect of the train speed of travel and the increase of axle load on different components of the rail fastening system. The range of speed that is considered includes 80, 100, 120, and 160 km/h and the axle loads were chosen as follows: 25, 30, 35 and 40t. After the analysis the following conclusions have been drawn:

- Increasing the lateral to vertical load ratio by keeping vertical load constant from 0.1 to 0.5, the deformation increases up to 40% compared to the increase of speed from 80 to 160 km/h.

- Increase of axle load from 25t to 40t causes the deformations to increase up to 13% compared to the increase of speed. It means that the increase of axle load is more effective than increasing the speed.

- One side of the fastening system deforms on a higher rate than the other depending where the lateral force is applied.

- In order to gain more understanding of the mechanical behavior of the fastening components, it is recommended to carry out a parametric study and determine the robust model under different axle load and speeds.

- It is also recommended to provide the fastening systems in curves that are more resistive compared with the ones in tangent tracks. Simply because in a curve there is a high demand of lateral load. Measures, like, using friction sleeper, widening the curve, use of under sleeper-pads, smaller sleeper spacing and constraining the sleepers have to be taken to increase the track lateral stability.

#### Acknowledgement

The authors would like to acknowledge the contribution made by Dr. Celestin Nkundineza for his help in understanding the software program.

#### Declaration of Conflicting Interests

The authors declare no potential conflicts of interest with respect to the research, authorship and publication of this article.

#### Funding

The author(s) received no financial support for the research, authorship, and/or publication of this article.

#### References

- [1] T.D.C Bizarria, Multifaceted approach for the analysis of rail pad assembly response, M.Sc. Thesis, University of Illinois Urbana-Champaign, (2014).
- [2] J. Sadeghi, Ballasted Railway Tracks: Fundamentals of Analysis and Design, IUST Publication Service, Tehran, Iran, (2010).
- [3] Xiao Hong, Guo Xiao, Wang Haoyu, Ling Xing, Wu Sixing, Fatigue damage analysis and life prediction of e-clip in railway fasteners based on ABAQUS and FE-SAFE, *Advances in Mechanical Engineering*, Vol. 10(3), (2018), pp. 1–12.
- [4] Mohammad Fesharaki, Amin Khajehdezfuly, Influences of train speed and axle loads on life cycle of rail fastening clips, *Transactions of the Canadian Society for Mechanical Engineering*, Vol. 39, No. 1, (2015).
- [5] Brent A. Williams, Donovan Holder, Marcus Dersch, Riley Edwards, Christopher Barkan, Quantification of lateral forces in concrete crosstie fastening systems, *Transportation Research Board 94th Annual Meeting*, Jan. (2015).
- [6] Thiago B. do Carmo, J. Riley Edwards, Ryan G. Kernes, Bassem Andrawes, Chris P.L. Barkan, Laboratory and field investigation on the railpad assembly mechanistic behavior, *Joint rail Conference 2014*, Colorado, USA.
- [7] J. Sadeghi, Investigation on the fatigue phenomena in the railway track fastening systems and design of fatigue testing machine, *Research Program Report 348F15*, Iranian Railway Research Center, (2007).
- [8] B.G.J. Holder, Y. Qian, M.S. Dersch, J.R. Edwards, Lateral load performance of concrete sleeper fastening systems under non-ideal conditions, *Proceedings of the 11<sup>th</sup> International Heavy Haul Association Conference (IHHA 2017)*, Cape Town, South Africa.
- [9] B.W. Williams, J.R. Edwards, M.S. Dersch, C.P.L. Barkan, R.G. Kernes, Experimental field investigation of the effects of lateral load distribution on concrete crosstie track, *AREMA, Annual Conference 2014*.

- [10] M. Oregui, A. de Man, M.F. Woldekidan, Z. Li, R. Dollevoet, Obtaining railpad properties via dynamic mechanical analysis, *Journal of Sound and Vibration*, 363, (2016), pp. 460–472.
- [11] B.J. Van Dyk, J.R. Edwards, C.J. Ruppert Jr., C.P.L. Barkan, Considerations for mechanistic design of concrete sleepers and elastic fastening systems in North America, *Rail Transportation & Engineering Center (RailTEC), University of Illinois at Urbana-Champaign (UIUC), Urbana, IL, USA*, (2012).
- [12] Zefeng Wen, Xuesong Jin, Weihua Zhang, Contact-impact stress analysis of rail joint region using the dynamic finite element method, *Wear* 258, (2005), pp. 1301–1309.
- [13] Javad Sadeghi, Mohammad Fesharaki, Amin Khajehdezfuly, Influence of train speed and axle loads on life cycle of rail fastening clips, *Transactions of the Canadian Society for Mechanical Engineering*, Vol. 39, No. 1, (2015).
- [14] M. Oregui, Z. Lin, R. Dollevoet, An investigation into the modeling of railway fastening, *International Journal of Mechanical Sciences*, 92, (2015), pp. 1–11.
- [15] Puguh B. Prakoso, The basic concepts of modelling railway track systems using conventional and Finite Element Methods, *INFO TEKNIK 2012*, Vol. 13, No. 1.
- [16] ANSYS Workbench User's Guide, Release 12.1, (2009).
- [17] A. Ortega García, Numerical and experimental analysis of the vertical dynamic behaviour of a railway track. Measurement of the vertical displacements and assessment of norms, M.Sc. Thesis, Faculty of Civil Engineering and Geosciences (CEG), Delft University of Technology, (2014).
- [18] RIJEKA, Constitutive modeling and material behavior, University of Rijeka, Faculty of Engineering, Interim Report, Biomat Project, (2016).
- [19] Shen-Haw Ju, Finite element investigation of traffic induced vibrations, *Journal of Sound and Vibration*, Vol. 321, Issue 3, (2009), pp. 837-853.
- [20] L. Hall, Simulations and analyses of train-induced ground vibrations in finite element models, *Soil Dynamics and Earthquake Engineering*, Vol. 23, Issue 5, (2002), pp. 403-413.
- [21] D. Kurhan, Determination of load for quasi-static calculations of railway track stress-strain State, *Acta Technica Jaurinensis*, Vol. 9, No. 1, (2016), pp. 83-96.
- [22] Zhe Chen, Mechanistic analysis of concrete crosstie and fastening system using field-validated Finite Element Model, M.Sc. Thesis, University of Illinois at Urbana-Champaign, (2015).
- [23] N.F. Doyle, *Railway Track Design, A Review of Current Design*, Australian Publishing Service, (1980).
- [24] D.A. Lange, R.G. Kernes, J.R. Edwards, M. Dersch, C.P.L. Barkan, Investigation of the dynamic frictional properties of a concrete crosstie rail seat and pad and its effect on rail seat deterioration (RSD), *Proc. Transportation Research Board 91st Annual Meeting 2012*, Transportation Research Board, Washington, D.C. 20001.
- [25] G. Stachowiak, A.W. Batchelor, *Engineering Tribology*, Elsevier Science, (2013).
- [26] Y. Yamaguchi, *Tribology of plastic materials: Their characteristics and applications to sliding components*, Elsevier Science, (1990).
- [27] National Standards for the People's Republic of China, Code for Design of Railway Line, GB 50090-2006.
- [28] Jabbar Ali Zakeri, Seyed Ali Mosayebi, Study of ballast layer stiffness in railway tracks, *GRAĐEVINAR* 68, 4, (2016), pp. 311-318.
- [29] W. Powrie, L.Le Pen, *A guide to track stiffness*, Cross Industry Track Group, (2016).
- [30] Paulos Tibebu, Structural response evaluation of concrete sleeper under increasing train speed and axle load, M.Sc. Thesis, Addis Ababa University, (2016).