



Reviewing and Comparing Different Algorithms and Topologies to Control the Speed of Multi Electric Train Motors by a Drive System

Soheil Ghaderi Talkhab¹, Roozbeh Asad^{1*}

¹Iran University of Science and Technology

ARTICLE INFO

Article history:

Received: 07.15.2023

Accepted: 08.30.2023

Published: 09.05.2023

Keywords:

Multi-motor drive

Multi-output inverter

Drive algorithm

Traction motor

Electric railway

ABSTRACT

With the growing trend of electrification in the rail transportation industry, the control system of electric motors plays a crucial role. Typically, each metro train consists of multiple wagons, and each wagon is equipped with several electric motors. In the conventional transportation system, each electric motor of the train is powered by a three-phase inverter, which increases the cost of the drive system and requires more space. Alternatively, another method involves using a three-phase inverter to control multiple electric motors, but this approach cannot independently control each motor. This paper provides a comprehensive review along with a comparative analysis of single-input multiple-output inverter topologies, along with some suggestions for selecting suitable configurations for electric transportation applications, particularly electric railways, to achieve independent control of each electric motor. Modern railway systems utilize multiple electric motors/drives for various functions such as traction, braking, steering, and suspension. As the number of electric motors in a train increases, challenges and issues arise in terms of cost, space, reliability, control, and energy management. This paper presents various architectures for power inverters to reduce the number of components and achieve centralized control in train bogies, different methods of motor synchronization in multi-motor drive systems, control algorithms for single-motor drive systems, and their extensions to various multi-motor drive structures.

1. Introduction

In industrial applications, typically each electric motor is driven by an inverter. With the rapid development of industries, the conventional single motor-single inverter system cannot meet the requirements of industrial applications such as electric railways and high-power drive systems. On the other hand, a multi-motor drive system can simultaneously and synchronously drive multiple motors. Nowadays, with the growing trend of electrification in the railway industry, multiple motors are used for various functions in the traction system, including traction, braking, and suspension. The single-input, multiple-output

inverter architecture for power inverters, with reduced components and centralized control, provides a promising solution [1,2]. The structure and control method of a multi-motor drive system depend on its application, as well as its performance requirements in terms of speed and accuracy [3]. For applications that do not require very high dynamic performance, a multi-motor drive system with multiple inverters using a V/f control strategy is described in [4]. Another control method based on the V/f strategy for modular CSI (current source inverter) drives for medium voltage multi-motor drives is presented in [5]. The idea of using an inverter to control two induction motors for a

*Corresponding author
Email address: asad@iust.ac.ir

locomotive was first introduced in 1984 [6], where two induction motors in the locomotive structure were connected in parallel, but independent control of the motors was not possible. In a subsequent paper in 2009 [7], the use of a dual-output inverter, a key element for supplying two AC consumers, was proposed. The single inverter drive system is widely used in electric traction systems such as railways, and its advantages include lower cost, reduced weight, compact structure, and fewer power switches [8]. However, the difference in radius and wheel slip in each bogie severely limits the development of this traction system due to safety concerns and the decreased performance of induction motors [9]. The authors in [10,11] have also proposed a weighted vector voltage control (WVVC) strategy for controlling the slip of two electric motors. A systematic review of multi-motor drives based on coupling and mutual influence has been presented in [12], where drives are classified based on the degree of mechanical coupling between the machines. Multi-phase induction machines and multi-motor drives powered by an inverter have also been extensively studied in [13]. With the additional degrees of freedom available in such machines, it is possible to obtain independent control for each machine with series or parallel connections. Control schemes for multi-motor drives using a three-leg inverter can generally be classified as average control and master-slave control. Both cases can also be considered weighted average control with equal weights of 0.5 and 0.5 for the average control method and 0 and 1 for the master-slave control method, where in this case, 1 is assigned to the controlled machine and 0 is assigned to the machine connected in parallel to the main machine [3]. Recently, researchers have focused on the control of multi-leg inverters (MLI) and control algorithms for multi-motor systems in the field of single inverter drives. In the control of multi-leg inverters, commonly used structures include five-leg, four-leg, and nine-switch inverters for driving two electric motors [14-16]. Furthermore, in a multi-motor drive system, it is possible to add sensorless speed control methods to the algorithms. For example, in [17], the researcher introduced a sensorless speed control method in the vector control model of dual-induction motor drives. Additionally, when an inverter is used to control two loads, fault detection in the inverter becomes crucial. Therefore, any malfunction in the inverter circuit

should not affect the system's downtime [18]. In [19], two motors are controlled by separate 3-leg inverters. However, if an error occurs in one of the legs, it is detected by a block consisting of 12 thyristor switches. Then, the faulty leg is removed from the circuit, and the two 3-leg inverters are converted into a 5-leg inverter to simultaneously control both motors.

2. Motor-Inverter Connection Topologies

Generally, two topologies can be considered:

- Parallel Connected Motor (PCM) Topologies; and
- Serial Connected Motor (SCM) Topologies.

Parallel-connected motors (PCM) are the simplest available topology. As the name suggests, the motors are connected in parallel to each other and to a three-phase inverter. In this method, a single inverter is used, regardless of the number of motors. The most obvious drawback of this method is that all motors must operate at the same voltage and frequency, although they can have different loads, torques, and even different currents [1,20,21]. Connecting motors in parallel to one inverter is often used in several industrial applications, such as railway applications, because it is a more cost-effective system compared to a conventional single-motor single-inverter drive [5,20]. Similar to the parallel connection topology, in the serial connection topology, a voltage source inverter (VSI) is used. However, in this method, all motors are connected in series. In this configuration, the motors will have the same current, so the load torques must be equal. However, the voltages of each motor can be different, and different speeds can also be achieved using this method [1]. Of course, it is important to note that in three-phase machines, the lack of additional degrees of freedom does not allow series connections [22].

2.1. Comparison of Motor-Inverter Connection Topologies

In the series-connected motor topology, due to limited controllability, reduced output voltage, and decreased motor efficiency, they are not suitable for power drive applications. However, this topology can provide cost reductions in industrial multi-motor drive systems where

efficiency is not a primary concern. On the other hand, although the parallel motor topology has many of the mentioned drawbacks, it does not suffer from reduced output voltage and can be used for standard motors. Therefore, it can offer a cost-effective solution for applications where the speed and torque requirements are the same for all motors [1].

3. Inverter Configurations Used in Multi-Motor Drive Systems

In the multi-motor drive system, a 3-leg inverter [23] or multi-leg inverters such as 4 legs, 5 legs, and 9 switches can be used to drive two electric motors [24-26]. In the multi-leg inverter structure, the voltage vector of both motors is controlled to improve the performance of the drive system. The most common method among multi-leg inverter structures is to use a five-leg inverter to control the drive system, which is reviewed in [27]. However, it goes without saying that the multi-leg inverter increases the number of capacitors in some cases [28].

3.1. Three-Leg Inverter

In multi-motor drive systems, the number of power electronic switches is of great importance. To optimize the system, sharing each leg of the inverter between two parallel-connected motor phases can result in a reduction in the number of switches. In such a system, the DC bus voltage remains constant, so both motors need to operate at a fixed speed.

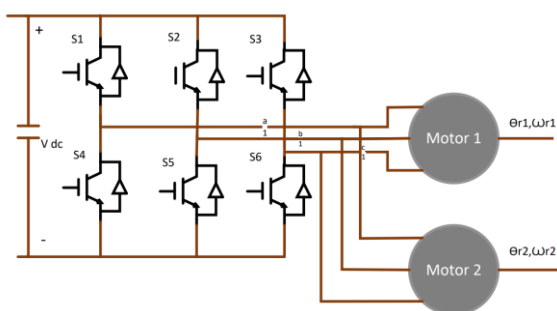

Figure 1. Parallel connection of two motors to a 3-leg inverter [24].

Therefore, generally speaking, this method has the advantages of fewer switches, lower cost, and smaller dimensions. The main drawback of this method is the inability to independently control each motor. For this inverter, two control algorithms are used: averaging and the master-

slave method [24,29]. For example, in the master-slave control method for controlling permanent magnet synchronous motors with a 3-phase inverter, vector control is applied to the main motor while open-loop control is used for the slave motor. If the loads of the two motors are different, oscillations in the speed of the slave motor occur due to differences in rotor positions [30,31]. In the averaging method, an additional block is added to the drive control algorithm that measures the required values of the motors and calculates their average; in this case, all motors are considered one motor [32-34]. The choice of control strategy significantly affects the torque response for machines with lower power compared to machines with higher power, resulting in faster torque dynamic responses. Therefore, it can be concluded that averaging control has better overall dynamic response compared to master-slave control, especially for machines with lower power and large load differences [35].

3.2. Four-Leg Inverter

This method is also used to reduce the number of power switches and the size of the drive system. As evidenced in Figure (2), one phase of both motors is connected to the capacitor leg of the inverter. Therefore, this type of inverter requires two capacitors to divide the phase voltage of one inverter into two parts [25]. Moreover, a 4-leg voltage inverter can produce eight active voltage vectors and one zero voltage vector [36].

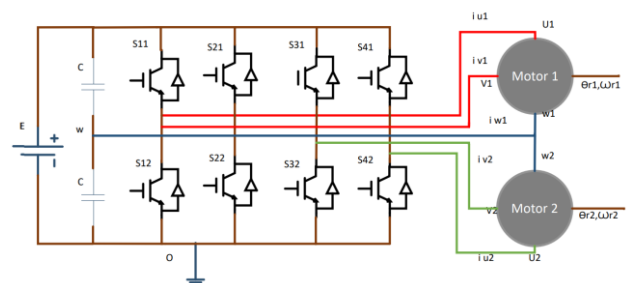

Figure 2. Four-Leg Inverter Configuration [25].

Some advantages of this inverter include fewer power switches compared to separate drives for each motor, smaller dimensions, the ability to independently control the speed of each motor separately, and independent control of the

position of each motor separately. One of the disadvantages of this structure is that in the case of capacitor imbalance, motor balancing and, consequently, motor control may not be performed correctly [25,37].

3.3. Nine Switch Inverter

In theory, a nine-switch inverter (NSI) can independently control two AC loads. The main advantage of using a nine-switch inverter is the reduction in the number of semiconductor switches. In a conventional approach, two parallel voltage source inverters require 12 semiconductor switches. In contrast, a nine-switch inverter only requires nine switches, resulting in a 25% reduction in the overall amount of switching devices and associated driver circuits. Additionally, a typical system requires six active gate drivers and six inactive gate drivers. On the other hand, a nine-switch inverter requires six active gate drivers and three inactive gate drivers. This feature significantly reduces the weight and size of the drive system and improves reliability since fewer switches are involved [26]. On the other hand, in this type of inverter, the torque and current ripple are high due to the presence of three common switches between the two motors [38].

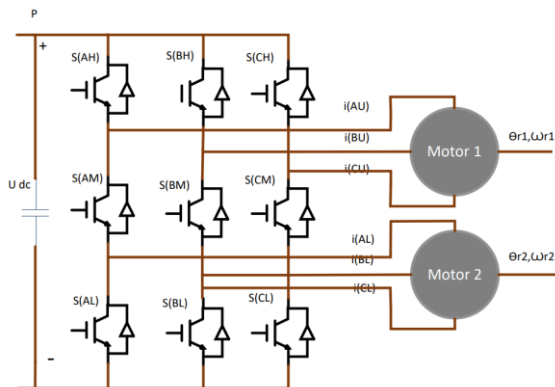

Figure 3. Nine Switch Inverter [38].

3.4. Five-leg inverter

The five-leg inverter structure has a simpler design compared to other structures, which is why it is used for separately controlling two electric motors. As shown in Figure (4), one phase of each motor is commonly connected to one leg of this inverter. Consequently, this structure saves the use of two power electronic switches.

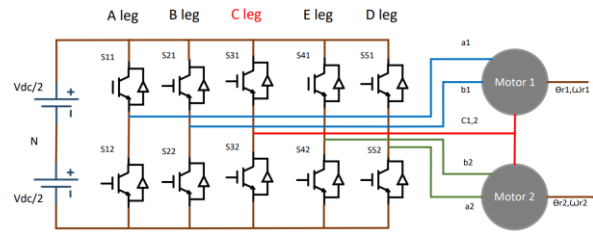

Figure 4. Powering two electric motors by a 5-leg inverter [27].

In this structure, it should be noted that the common leg must have the capability to withstand higher currents as well. This structure possesses all the advantages of the previous structures and can be used in a fault-tolerant mode [27]. Another important point in this structure is that the switches on one leg should not be turned on at the same time. Because it leads to a short circuit of the DC source. Similarly, the switches on each leg cannot be turned off together either to avoid undefined modes in the inverter [18].

3.5. Comparison of Inverter Configurations

Table (1) provides a comparison of inverter losses and switch capacity between two voltage source three-leg inverters (2-VSI), a five-leg inverter (FLI), and a nine-switch inverter (NSI) when driving both motors independently. Each value in the table is normalized with respect to the value of the 2-VSI.

Table 1. Comparison of Inverter Configurations [39].

	Double 3-leg inverter	5-leg inverter	9-switch inverter
Number of Switches	12	10	9
Inverter Losses	1	1	1.25
A Voltage	1	1	1
Current	1	1	1
Dc link voltage	1	2	2
Inverter Losses	1	2	2.5
B Voltage	1	0.5	0.5
Current	1	2	2
Dc link voltage	1	1	1
Switch Capacity	1	2	2.5

Table (1) displays the voltage and current values necessary to achieve maximum output.

- In the FLI configuration, the maximum current flowing through the common leg is twice that of the current flowing through all switches on the 2-VSI or through the switches on the other legs of the FLI.
- In the NSI configuration, the maximum amplitude of the current flowing through all switches is twice that of the current flowing through all switches on the 2-VSI.
- Compared to the 2-VSI, both the FLI and the NSI exhibit increased inverter losses and switch capacity. Although the 2-VSI has the highest number of switches, it experiences the most significant decrease in inverter losses and switch capacity.
- The NSI offers the advantage of reducing the number of switches compared to the 2-VSI and FLI configurations. However, this reduction in the number of switches results in increased inverter losses and switch capacity for the NSI configuration [39].

4. Methods of synchronizing motors in a multi-motor drive system

A successful synchronization technique in a multi-motor system should involve the control of two mechanical motor variables, namely speed and torque. The methods used in single-input-single-output systems may provide stability at static operating points. However, they cannot guarantee desirable control of output values in dynamic states. Additionally, an additional issue that often arises in multi-motor control systems is the significant delay of control signals and the presence of disruptive signals.

The classification of multi-motor control strategies can be divided into three main categories: classical control strategy, modern control strategy, and intelligent control [40,41].

4.1. Classical Control Strategies in Multi-Motor Control

Classical control strategies in multi-motor control are based on PI (Proportional-Integral) or PID (Proportional-Integral-Derivative)

controllers. They can be divided into parallel control, master-slave control, and cross-coupling control.

In the parallel control strategy, as shown in Figure (5a), a reference signal is sent in parallel to all drive units. This control strategy is simple but lacks feedback signals, so in the event of a disturbance, the simultaneous operation of the drive units is compromised.

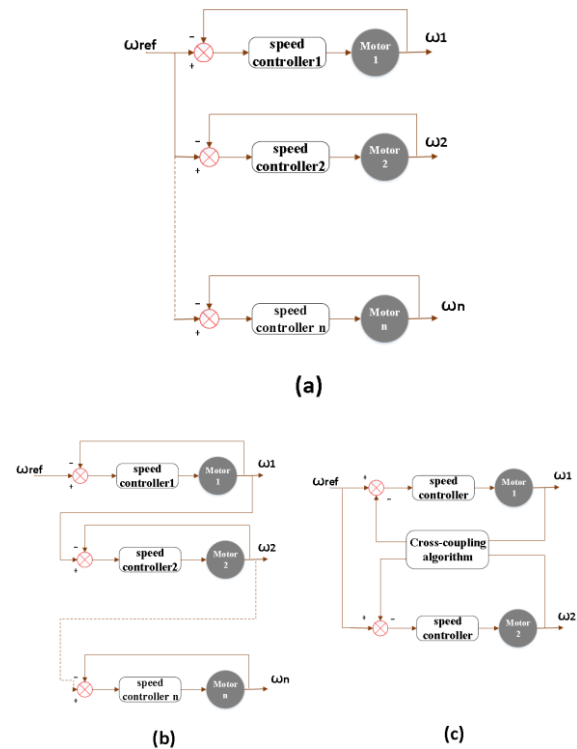

Figure 5. Classical multi-motor control strategies: (a) parallel control, (b) master-slave control, (c) cross-coupling control [40].

In the master-slave control strategy, as shown in Figure (5b), the speed of one drive becomes the reference signal for the next drive unit. In this way, the speed of the slave motor always tracks the speed changes of the preceding motor. However, in the event of disturbances in the slave drive unit, the synchronization of the motors cannot be maintained because there is no feedback from the slave units, and the preceding motors also do not track the speed changes. After such a disturbance, the speed of all motors will eventually equalize after a certain delay, but synchronization does not imply a recoverable position.

The cross-coupling control strategy, depicted in Figure (5c), establishes coupling relationships between all motor units in the system. This approach ensures high control accuracy and

tracking performance, and in the event of disturbances, the coordination between the motors will be maintained. However, the complexity of this strategy significantly increases with the number of controlled drive units, and as mentioned, it may lead to system instability in cases that require high synchronization accuracy [40].

4.2. Modern Strategies for Multi-Motor Control

Modern strategies for multi-motor control can be divided into the following categories:

1. Ring Coupling Control Strategy;
2. Relative Coupling Control Strategy;
3. Adjacent Coupling Control Strategy;
4. Combined Cross-Coupling Error Control Strategy; and
5. Coordinated Coupling Control Strategy [40].

4.2.1. Ring Coupling Control Strategy

The ring coupling control strategy combines the principles of classical multi-motor control strategies to ensure the synchronization of motors in the presence of disturbances at any point in the system while keeping the control structure relatively simple. Similar to the parallel control strategy, this approach utilizes only one reference speed signal. Additionally, the speed of each motor is compared with the speed of the next motor and then adjusted by a compensator that generates an additional input signal in the drive unit. The speed of the last motor is compared with the speed of the first motor in the system, ensuring synchronization of all motors regardless of the location of the disturbance. This ultimately leads to the conclusion that controlling n motors requires $2*n$ controllers [40,42].

4.2.2. Relative Coupling Control

The relative coupling control strategy addresses the synchronization problem of the system during disturbances by considering all speed feedbacks to obtain additional control signals for each drive unit. The advantage of this approach is that all motor speed feedbacks are equally important, and the algorithm used to obtain additional control signals is relatively

simple [40]. Moreover, the traditional coupling control structure can be improved with an additional speed controller so that all motors in the system can be considered entities. It also considers the importance of the speed of each motor in the processes of speed feedback and synchronous speed compensation [43].

4.2.3. Adjacent Coupling Control Strategy

In the adjacent coupling tracking strategy, both a speed tracking controller and a speed synchronization controller are required for each motor. The speed tracking controller generates a control signal to track the reference speed value, while the speed synchronization controller is used to synchronize the speed between the controlled motor and its two neighboring motors. The outputs of these controllers are summarized in a motor torque command [40].

4.2.4. Combined Cross-Coupling Error Control

A new control strategy is proposed for complex multi-motor systems that involve a larger number of actuator units. The suggested strategy divides the complex multi-motor system into subsystems. There exists a main drive unit in the system that serves as the reference for synchronizing the subsystems, following a master-slave control strategy. Within each subsystem, there is a primary drive unit that serves as the main unit, and the coupling loop strategy is employed for synchronizing the drives within the subsystem. [40,44].

4.2.5. Coordinated Coupling Control Strategy

In the coordinated coupling control strategy, alongside the main reference speed controllers and speed controllers in each drive unit, a coordinated controller is introduced, similar to the classical parallel control strategy. As mentioned, the coordinated controller is designed to quickly compensate for motor speed with the highest relative error while maintaining the stability of other motors. This controller needs to act quickly. Thus, coordinated controllers are often based on artificial intelligence techniques such as neural networks and fuzzy algorithms. Additionally, fuzzy logic control has been recognized as the most suitable technique for designing coordinated controllers

based on existing research. Examples of fuzzy algorithm-based coordinated control strategies will be discussed in the next section [40].

4.3. Intelligent Control Strategies

In classical and modern control strategies, the process of designing a control system requires the creation of precise mathematical models. However, in many industrial cases involving complex systems, developing accurate mathematical models can be challenging. To address such difficulties, intelligent control technology is employed to design controllers that can handle complex mathematical models. Synchronization control based on fuzzy controllers and neural networks is widely used in intelligent control strategies [41].

4.3.1. Synchronization based on Fuzzy Controllers

Fuzzy control theory considers the operator's experience as a criterion and examines and controls complex mathematical models. In this approach, the fuzzy mathematical model is expressed linguistically, and its structure is shown in Figure (6).

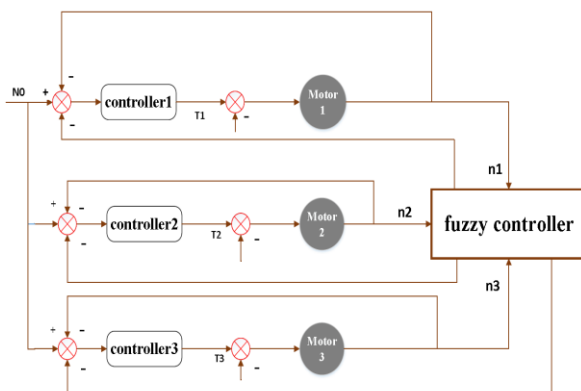

Figure 6. Improvement of the multi-motor control system based on fuzzy control [41].

In this system, the coupling relationship between the output speeds of different motors depends on the fuzzy controller and the speed-compensating feedback. The fundamental principle of the fuzzy controller is based on the speed error and the differential speed error to develop fuzzy control rules. It then compares the actual speed with the desired speed. In this method, a processor is used to evaluate the

comparison result, and a speed-compensating feedback actuator is employed [41].

4.3.2. Synchronization Control based on Neural Network

Neural network control is a pioneering topic in the field of automatic control that emerged in the late 1980s. It represents a new branch of intelligent control that provides a novel approach to solving control problems in complex nonlinear systems. Neural network control mainly consists of three components: neural network structure, neuron model, and network learning. The neuron model can be considered as a multi-input and single-output model. The neural network control method can ensure precise load control based on the assurance of speed synchronization between two electric motors. Additionally, this method separately controls the speed and load, and it also exhibits the good dynamic performance of the system [41,45].

4.4. Comparison of Multi-Motor Control Strategies

Each control strategy presented in the previous sections has its advantages and disadvantages. The most suitable control strategy for a multi-motor system should be selected based on the specific requirements of the system and the characteristics of the control strategy. A detailed comparison of synchronization strategies is provided in Table (2).

For example, in continuous production lines, it is often more important for a specific motor to follow the speed of the previous motor in the system until it reaches the desired reference speed. In this case, the master-slave control can be a good option for continuous lines without the need for position synchronization. However, if the continuous line is a highly complex system that requires synchronized positioning of certain subsystems, a combined error control approach may be a suitable choice. On the other hand, these two methods are not optimal for robotics applications. Therefore, in robotics, coordinated control is often preferred due to its simple control structure and minimal control signal delay, which are essential for robotics to achieve precise and responsive movements [40].

speeds are also determined using sensors, and in the speed control loop of these motors, a fuzzy controller or PI controller is employed.

In a control system of two motors driven by a three-leg inverter, the two existing motors are transformed into a virtual average motor through averaging. Therefore, the averages of the measured variables of the motors, namely the currents (I_{s1} , I_{s2}) and the speeds, are obtained from equation (1).

$$I_s = \frac{I_{s1} + I_{s2}}{2} \tag{1}$$

$$\Omega = \frac{\Omega_1 + \Omega_2}{2}$$

Furthermore, since both motors are transformed into a single motor using the averaging method, the rest of the algorithm is the same as the single-motor drive algorithm [32,50].

6.2. Dual motors drive system with FOC control and a 5-leg inverter

From the block diagram in Figure (8), it is evident that for a dual-motor drive, there are two separate three-phase algorithms that are exactly similar to the mentioned single motor algorithm, with the difference that there is a block in the final stages of the diagram responsible for merging these two algorithms and commanding the 5-leg inverter.

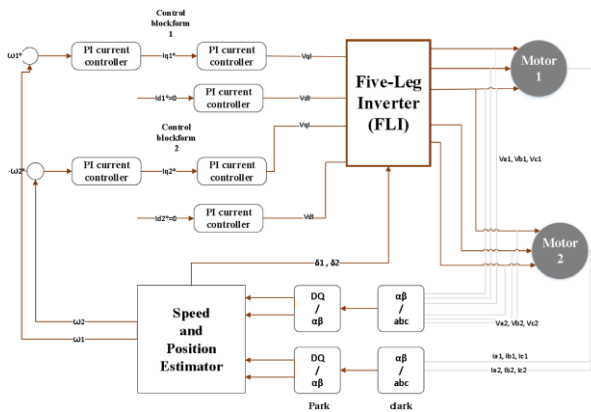

Figure 8. Block diagram of dual-motor drive by FOC method [51].

6.2.1. SVM modulation for 5-leg inverter

In this method, two separate SVM modulators are used for the two motors. The reference of each machine is transformed into 0dq domain

vectors with different positions in one of the six sectors.

The generated outputs from the three-phase inverter with the switching cycle and switching period are represented for each inverter leg. By simply adding up the generated switching cycles of each modulator, five different switching cycles can be determined for the five inverter legs. The duty cycle of each phase inverter can be described by equation (2):

$$\delta_A = \delta_{a1} + \delta_{c2}, \delta_B = \delta_{b1} + \delta_{c2}, \delta_c = \delta_{c1} + \delta_{c2},$$

$$\delta_D = \delta_{a2} + \delta_{c1}, \delta_E = \delta_{b2} + \delta_{c1} \tag{2}$$

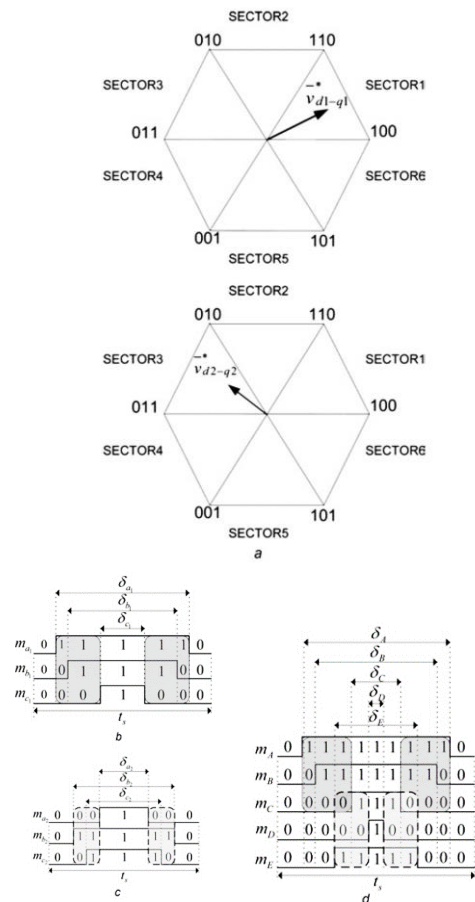

Figure 9. SVM modulation for dual motor control [52].

In Figure (9), part (a), a desired voltage vector $\vec{V}_{d1-q1}^* = 0.3V_{dc} \angle 45^\circ$ is selected for the first motor, and a vector $\vec{V}_{d2-q2}^* = 0.2V_{dc} \angle 140^\circ$ is selected for the second motor. The sequences and duty cycles of active switching vectors are shown inside the highlighted boxes in parts (b) and (c) of Figure 9.

In part (d), it can be observed that when applying this principle to a five-leg inverter, the

sequences of the two previous parts are still preserved. Additionally, it can be seen from part (d) that the zero vector switching time for both motors in the five-leg mode is different from the two previous parts, while the total number of zero vector switchings is the same in all parts.

Furthermore, part (d) shows that there are moments during the switching period where both machines receive their active vectors simultaneously.

In this modulator, D and E refer to phases “a” and “b” of the second machine, respectively. C is the common phase between the two machines, connected in parallel to each other. Therefore, the reference vectors of each machine are complements of the other machine, and the modulator is capable of simultaneously meeting the needs of both motors. Additionally, from part (d), it can be observed that in the remaining states, the reference vector v for one of the machines is a zero vector, so in these states, the needs of one machine are fulfilled while the second machine receives a zero vector [51,52].

6.3. Dual motors drive system with DTC control and a 5-leg inverter

To enhance the reliability of dual-motor drive systems, an improved Direct Torque Control (DTC) scheme is proposed for five-leg dual-PMSM drive systems. This scheme employs a master-slave selection principle to minimize system errors.

Obviously, since the inverter here is a five-leg inverter, five switching states are required, whereas there are normally six switching states. As mentioned earlier, the issue lies with phase C, which is the common leg. If the switching state of phase C is the same for both motors, no problem arises. However, if they differ, it leads to an implementation challenge since the switching of the common leg cannot be changed during one switching cycle. The purpose of this scheme is to address this implementation issue.

Investigating different switching states:

To clarify the analysis, the switching vector U is defined as Equation (3):

$$U_{10i+j} = (V_i, V_j), I = 0 \dots 7, j = 0 \dots 7 \quad (3)$$

Given equation (3), there are a total of 64

different keying vectors, as shown in Table 10. The keying vector is divided into three conditions:

- 1- First condition: $Kc1$ is equal to $Kc2$ (the keying of the common shaft of the two motors is equal).
- 2- Second condition: $Kc1$ is not equal to $Kc2$, but one of the keying vectors is zero.
- 3- Third condition: $Kc1$ is not equal to $Kc2$, and both keying vectors are active.

Table 3. Classification Of switching vectors [53].

$V_j \backslash V_i$	0	1	2	3	4	5	6	7
0	I	I	I	I	II	II	II	II
1	I	I	I	I	III	III	III	II
2	I	I	I	I	III	III	III	II
3	I	I	I	I	III	III	III	II
4	II	III	III	III	I	I	I	I
5	II	III	III	III	I	I	I	I
6	II	III	III	III	I	I	I	I
7	II	II	II	II	I	I	I	I

As it is clear from Table (3), in the first case, there are 32 switching modes, and since the third leg switching is equal, there is no problem in implementing this method. In the second case, there are 14 switching states, one of which includes zero vectors, i.e., V_0 and V_7 . Since these two vectors have the same control effects, each of them can be replaced by the other.

However, in the third case, both switching vectors are active, and there is no zero switching vector available. It is obvious that in this case, at least one active switching vector needs to be modified to solve the implementation problem. This means that in this case, both motors can no longer be controlled simultaneously, and the performance of one motor will be affected. The principles of solving this problem are addressed in the next section.

6.3.1. Master-Slave Selection Method

In the third case, since it is not possible to avoid changing the vector, one of the vectors is modified to reduce the performance degradation.

To evaluate the performance degradation, the error of the PMSM system with dual motors is defined by Equation (4).

$$F_{err1} = \left(\frac{\Delta T_{e1}}{T_{rated1}}\right)^2 + \lambda \left(\frac{\Delta \psi_{m1}}{\psi_{f1}}\right)^2 \quad (4)$$

$$F_{err2} = \left(\frac{\Delta T_{e2}}{T_{rated2}}\right)^2 + \lambda \left(\frac{\Delta \psi_{m2}}{\psi_{f2}}\right)^2 \quad (5)$$

In Equation (4), λ represents a constant coefficient, F_{err1} and F_{err2} are the system errors of motor 1 and motor 2, T_{rated1} and T_{rated2} are the rated torques of motor 1 and motor 2, and Ψ_{f1} and Ψ_{f2} are the magnetic fluxes of motor 1 and motor 2.

From Equation (4), it can be understood that the system errors are relative values that take into account the differences in parameters between motor 1 and motor 2. In other words, the new method can be used for two identical PMSM motors or two different motors.

In this method, the motor with a larger system error is defined as the main motor, and its switching vector is defined as the main switching vector, or the master. Similarly, the switching vector of the other motor with a smaller system error is selected as the secondary vector, or the slave.

In Table (3), it can be observed that in the single-motor DTC method, an appropriate switching vector is selected to minimize the absolute value of electromagnetic torque error and flux error, and this principle also applies in this case. If the selected switching vector is not applied, it causes an increase in system errors.

Ignoring the stator resistance, the stator flux vector Ψ_s remains unchanged. Now, if a zero switching vector is executed, according to Table (3), the active switching vector is only selected when ΔT_e is positive.

If the selected switching vector is replaced by a zero vector, $|\Delta T_e|$ becomes larger, and the system error also increases. However, when the system error of the slave motor becomes larger than the system error of the main motor, their roles are immediately swapped. Therefore, one motor cannot always be the slave.

6.3.2. Control Method

The control flowchart for the dual-motor control is provided in Figure (10). Initially, each

of the motors is operated using the single-motor control method, and then the switching mode for the phases is determined according to the following steps.

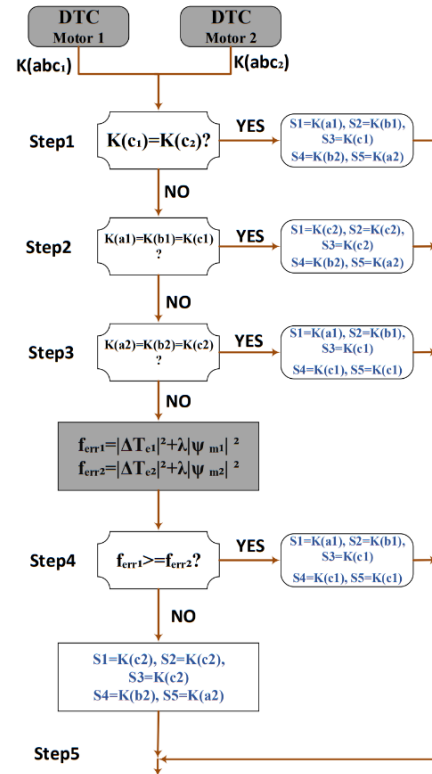

Figure 10. Control flowchart [53].

Flowchart Explanation:

Step 1: If K_{c1} is equal to K_{c2} , the switching modes for the five-leg inverter are determined as follows, and it then proceeds to the final step:

$$S_1=k_{a1}, S_2= k_{b1}, S_3=k_{c1}, S_4=k_{b2}, S_5=k_{a2} \quad (6)$$

Step 2: If K_{abc1} (switching vector of the first motor) is the zero switching vector (V_0 or V_1), the switching modes are as follows, and it then proceeds to the final step:

$$S_1=k_{c2}, S_2= k_{c2}, S_3=k_{c2}, S_4=k_{b2}, S_5=k_{a2} \quad (7)$$

Step 3: If K_{abc2} (the switching vector of the second motor) is the zero switching vector (V_0 or V_1), the switching modes are as follows, and it then proceeds to the final step:

$$S_1=k_{a1}, S_2= k_{b1}, S_3=k_{c1}, S_4=k_{c1}, S_5=k_{c1} \quad (8)$$

Step 4: When the F_{err1} is greater than F_{err2} , the first motor is selected as the master and the second motor is selected as the slave. In this case, the switching modes are the same as in Step 3. Conversely, if the system error of the second

motor is greater, then the switching modes follow the same pattern as in Step 2.

In general, it should be noted that this dual-motor control method is not specific to a particular phase or specific motor. Therefore, this method is a general approach for a dual-motor drive using a five-leg inverter [53].

6.4. Hysteresis Current Control Method by a Five-Leg Inverter

In the hysteresis control method, there is no requirement for any machine parameters, which greatly increases the reliability of this method. The advantages of the hysteresis control (HCC) method include easy implementation, fast response, independent parameters, current limiting, and high accuracy.

Figure (11) displays the hysteresis band of a three-phase motor drive. As evident in the image, in this method, after generating the reference current for each phase, it is summed with the negative actual current of each phase, and then the response is sent to the hysteresis block.

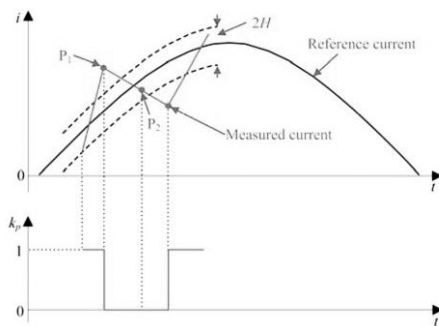

Figure 11. Measured current and reference diagram in hysteresis method [54].

To control a three-phase motor using a three-level inverter through the hysteresis control method, the coefficient K is selected for the hysteresis band, which is defined by the following formula:

$$K_p = \begin{cases} 1, \Delta i_p > H \\ 0, \Delta i_p < -H \end{cases} \quad (9)$$

In Equation (8), Δi_p , the phase current error is defined as the difference between the measured current and the reference current. Here, P represents each of the phases, and H denotes the hysteresis band. As the formula indicates, if the phase current exceeds the

hysteresis band, the command to turn off the switch is issued at that moment. Conversely, at another point, if the difference between the reference current and the measured current becomes positive, the "one" state occurs, and the command to turn on the switch is issued. This way, the current is controlled.

Now, for the dual-motor drive, two three-phase hysteresis blocks are combined to enable the switching of a five-level inverter. For this purpose, the reader is referred to the switching of each phase as described in Equation (9):

$$S_1=k_{A1}, S_2=k_{B1}, S_5=k_{A2}, S_4=k_{B2} \quad (10)$$

In Equation (9), there is no mention of the third phase of the motors or the common leg of the inverter. Therefore, the following discussion is about the common leg, which will be examined as to how its switching is performed.

Table 4. Hysteresis band modes for common leg [54].

	Freedom of Phase-C ₁	Freedom of Phase-C ₁
FC1	Free(Δi_{c1} <H)	Unfree(Δi_{c2} >H)
FC2	Unfree(Δi_{c1} >H)	Free(Δi_{c2} <H)
FC3	Unfree(Δi_{c1} >H)	Unfree(Δi_{c2} >H)
FC4	Free(Δi_{c1} <H)	Free(Δi_{c2} <H)

In the first and second scenarios, one of the motors has a current difference within the hysteresis band, while the other motor has a current difference outside this band. In this case, the motor that has exceeded the hysteresis band is considered the primary motor, and its phase is applied as the primary phase to the common shaft.

However, in the third scenario, both motors have current differences outside the hysteresis band. In such cases, the absolute values of the currents of both motors are compared, and the motor with a higher value exceeding the band is selected as the primary motor. This strategy helps minimize the current error.

In the third scenario, none of the motors have exceeded the hysteresis band, but tasks will still be operated according to the same strategy as in the third scenario mentioned above [54].

7. Conclusion

In conclusion, in electric railway industry applications, multiple bogies often require a variable-speed electric motor. In most cases, these multi-motor drive systems also require synchronous control of the motors. If each motor were to be controlled separately in a conventional manner, it would require significant cost and space. In this paper, research efforts have been made to reduce the number of required power electronic devices in multi-motor drive systems to reduce overall complexity, required space, and consequently, the cost of the drive. Considering different control areas for the synchronous control of two motors, three control strategies including vector control, DTC, and hysteresis control for the dual-motor drive using 5-Leg, 4-leg, and Nine switch inverters with PWM and SVM modulations have been proposed as reliable and practical solutions. In fact, by using a single inverter to control two motors, it is possible to reduce the number of power switches by at least 2 and up to 4 compared to the conventional approach without compromising the independent control of each bogie's motors. Therefore, the methods mentioned in this paper offer an efficient and highly reliable approach to reducing the costs of electric motor control systems and increasing space in electric train bogies.

References

- [1] M. al Sakka et al., "Comparative Analysis of Single-Input Multi-Output Inverter Topologies for Multi-motor Drive Systems," in 2020 15th International Conference on Ecological Vehicles and Renewable Energies, EVER 2020, 2020. doi: 10.1109/EVER48776.2020.9243097.
- [2] H. Wan and Y. Pan, "A single-inverter multi-motor system based on direct torque control," UPB Scientific Bulletin, Series C: Electrical Engineering and Computer Science, vol. 76, no. 2, 2014.
- [3] B. M. Joshi and M. C. Chandorkar, "Two-motor single-inverter field-oriented induction machine drive dynamic performance," Sadhana -Academy Proceedings in Engineering Sciences, vol. 39, no. 2, 2014, doi: 10.1007/s12046-014-0237-6.
- [4] J. Iyer, K. Tabarraee, S. Chiniforoosh, and J. Jatskevich, "An improved V/F control scheme for symmetric load sharing of multi-machine induction motor drives," in Canadian Conference on Electrical and Computer Engineering, 2011. doi: 10.1109/CCECE.2011.6030711.
- [5] J. D. Ma, B. Wu, N. R. Zargari, and S. C. Rizzo, "A space vector modulated CSI-based ac drive for multimotor applications," IEEE Trans Power Electron, vol. 16, no. 4, 2001, doi: 10.1109/63.931075.
- [6] H. C. Skudelny and M. Weinhardt, "An Investigation of the Dynamic Response of Two Induction Motors in a Locomotive Truck Fed by a Common Inverter," IEEE Trans Ind Appl, vol. IA-20, no. 1, 1984, doi: 10.1109/TIA.1984.4504391.
- [7] C. Liu, B. Wu, N. R. Zargari, D. Xu, and J. R. Wang, "A novel three-phase three-leg AC/AC converter using nine IGBTs," IEEE Trans Power Electron, vol. 24, no. 5, 2009, doi: 10.1109/TPEL.2008.2004038.
- [8] B. Tabbache, A. Kheloui, and M. E. H. Benbouzid, "An adaptive electric differential for electric vehicles motion stabilization," IEEE Trans Veh Technol, vol. 60, no. 1, 2011, doi: 10.1109/TVT.2010.2090949.
- [9] N. Mutoh, T. Kazama, and K. Takita, "Driving characteristics of an electric vehicle system with independently driven front and rear wheels," IEEE Transactions on Industrial

Electronics, vol. 53, no. 3, 2006, doi: 10.1109/TIE.2006.874271.

[10] F. Xu, L. Shi, K. Wang, and Y. Li, "A control strategy of dual induction motors fed by single inverter for traction system," in IEEE Transportation Electrification Conference and Expo, ITEC Asia-Pacific 2014 - Conference Proceedings, 2014. doi: 10.1109/ITEC-AP.2014.6940961.

[11] K. Eshwar and V. K. Thippiripati, "Weighting-Factorless Predictive Torque Control Scheme for Dual Inverter fed Open-End-Winding PMSM with Single DC Source," IEEE Trans Power Electron, vol. 36, no. 11, 2021, doi: 10.1109/TPEL.2021.3077665.

[12] "International Symposium on Power Electronics, Electrical Drives, Automation and Motion," International Symposium on Power Electronics, Electrical Drives, Automation and Motion, 2006. SPEEDAM 2006, vol. 2006. 2006.

[13] E. Levi, M. Jones, S. Vukosavic, and H. A. Toliyat, "A novel concept of a multiphase, multimotor vector controlled drive system supplied from a single voltage source inverter," IEEE Trans Power Electron, vol. 19, no. 2, 2004, doi: 10.1109/TPEL.2003.823241.

[14] I. Zhurov, S. Bayda, and S. Florentsev, "Field-Oriented Control of the Cargo Locomotive Induction Motor Electric Drive When Using Single Power Converter Feeding Two Traction Motors," in Proceedings - ICOECS 2021: 2021 International Conference on Electrotechnical Complexes and Systems, 2021. doi: 10.1109/ICOECS52783.2021.9657434.

[15] A. Furuya, K. Oka, and K. Matsuse, "A characteristic analysis of four-leg inverter in two AC motor drives with independent vector control," in Proceeding of International Conference on Electrical Machines and Systems, ICEMS 2007, 2007. doi: 10.1109/ICEMS12746.2007.4412037.

[16] K. Matsuse, N. Kezuka, and K. Oka, "Characteristics of independent two induction motor drives fed by a four-leg inverter," IEEE Trans Ind Appl, vol. 47, no. 5, 2011, doi: 10.1109/TIA.2011.2161739.

[17] K. Matsuse, H. Kawai, Y. Kouno, and J. Oikawa, "Characteristics of Speed Sensorless Vector Controlled Dual Induction Motor Drive

Connected in Parallel Fed by a Single Inverter," IEEE Trans Ind Appl, vol. 40, no. 1, 2004, doi: 10.1109/TIA.2003.821805.

[18] S. P. Harish, S. Sridhar, O. Indela, G. Kodeeswara Kumaran, and P. Parthiban, "Analysis of Five Leg Voltage Source Inverter Fed Dual Motor Drive System," in E3S Web of Conferences, 2021, vol. 309. doi: 10.1051/e3sconf/202130901142.

[19] W. Wang, M. Cheng, B. Zhang, Y. Zhu, and S. Ding, "A fault-tolerant permanent-magnet traction module for subway applications," IEEE Trans Power Electron, vol. 29, no. 4, 2014, doi: 10.1109/TPEL.2013.2266377.

[20] Yeam, Tae-Il, and Dong-Choon Lee. "Design of sliding-mode speed controller with active damping control for single-inverter dual-PMSM drive systems." IEEE Transactions on Power Electronics 36.5 (2020): 5794-5801.

[21] Kelec, Patrick M., and Robert D. Lorenz. "Control methodology for single inverter, parallel connected dual induction motor drives for electric vehicles." Proceedings of 1994 Power Electronics Specialist Conference-PESC'94. Vol. 2. IEEE, 1994.

[22] B. M. Joshi and M. C. Chandorkar, "Effects of machine asymmetry on a two-machine direct torque controlled induction motor drive," Proceedings of the 2011 14th European Conference on Power Electronics and Applications, Birmingham, UK, 2011, pp. 1-10.

[23] Ahmed, Taibi, Hartani Kada, and Ahmed Allali. "New DTC strategy of multi-machines single-inverter systems for electric vehicle traction applications." International Journal of Power Electronics and Drive Systems 11.2 (2020): 641.

[24] Y. Lee and J. I. Ha, "Control method for mono inverter dual parallel interior permanent magnet synchronous machine drive system," in 2015 IEEE Energy Conversion Congress and Exposition, ECCE 2015, 2015. doi: 10.1109/ECCE.2015.7310399.

[25] S. Ito, T. Moroi, Y. Kubo, K. Matsuse, and K. Rajashekara, "Independent control of two permanent-magnet synchronous motors fed by a four-leg inverter," IEEE Trans Ind Appl, vol. 51, no. 1, 2015, doi: 10.1109/TIA.2014.2332637.

[26] O. Gulbudak and M. Gokdag, "Dual-Hysteresis Band Control of Nine-Switch Inverter to Control Two Induction Motors," IEEE

- Transactions on Energy Conversion, vol. 37, no. 2, 2022, doi: 10.1109/TEC.2021.3131385.
- [27] J. H. Lee, J. S. Lee, and J. H. Ryu, "Carrier-Based Discontinuous PWM Method for Five-Leg Inverter," IEEE Access, vol. 8, 2020, doi: 10.1109/ACCESS.2020.2998177.
- [28] Y. Matsumoto, S. Ozaki, and A. Kawamura, "A novel vector control of single-inverter multiple-induction-motors drives for Shinkansen traction system," in Conference Proceedings - IEEE Applied Power Electronics Conference and Exposition - APEC, 2001, vol. 1. doi: 10.1109/apec.2001.911710.
- [29] Bidart, Damien, et al. "Mono inverter dual parallel PMSM-structure and control strategy." 2008 34th Annual Conference of IEEE Industrial Electronics. IEEE, 2008.
- [30] T. il Yeam and D. C. Lee, "Design of Sliding-Mode Speed Controller with Active Damping Control for Single-Inverter Dual-PMSM Drive Systems," IEEE Trans Power Electron, vol. 36, no. 5, 2021, doi: 10.1109/TPEL.2020.3028601.
- [31] Liu, Tianyi, et al. "A MTPA control strategy for mono-inverter multi-PMSM system." IEEE Transactions on Power Electronics 36.6 (2020): 7165-7177.
- [32] Asri, Ahmad, et al. "A speed sensorless field oriented control of parallel-connected dual PMSM." 2011 IEEE International Conference on Control System, Computing and Engineering. IEEE, 2011.
- [33] Hamada, Fanniesha, Faiz Husnayain, and Feri Yusivar. "Speed Sensorless Vector Control of Parallel Connected Induction Motor with Anti-windup Integral-Proportional Speed Controller." 2019 IEEE 2nd International Conference on Power and Energy Applications (ICPEA). IEEE, 2019.
- [34] Montero, E. Rodriguez, M. Vogelsberger, and T. Wolbank. "Saliency Extraction and Torque Sharing Estimation of Dual Motor Drive using Special Current Sensor Configuration." 2022 24th European Conference on Power Electronics and Applications (EPE'22 ECCE Europe). IEEE, 2022.
- [35] Joshi, Bhakti M., and Mukul C. Chandorkar. "Two-motor single-inverter field-oriented induction machine drive dynamic performance." Sadhana 39 (2014): 391-407.
- [36] Y. Sangsefidi, S. Ziaeinejad, and A. Mehrizi-Sani, "A new two-motor drive to control a two-phase induction motor and a DC motor," in Proceedings - 2015 IEEE International Electric Machines and Drives Conference, IEMDC 2015, 2016. doi: 10.1109/IEMDC.2015.7409154.
- [37] Shi, Tingna, et al. "Improved relative coupling control structure for multi-motor speed synchronous driving system." IET Electric Power Applications 10.6 (2016): 451-457.
- [38] Y. Pang et al., "Model predictive control of nine-switch converter with output filter for independent control of two loads," Journal of Power Electronics, vol. 21, no. 1, 2021, doi: 10.1007/s43236-020-00145-0.
- [39] Oka, Kazuo, et al. "Characteristic comparison between five-leg inverter and nine-switch inverter." 2007 Power Conversion Conference-Nagoya. IEEE, 2007.
- [40] V. J. Štil, T. Varga, T. Benšić, and M. Barukčić, "A survey of fuzzy algorithms used in multi-motor systems control," Electronics (Switzerland), vol. 9, no. 11. 2020. doi: 10.3390/electronics9111788.
- [41] H. Huang, Q. Tu, C. Jiang, L. Ma, P. Li, and H. Zhang, "Dual motor drive vehicle speed synchronization and coordination control strategy," in AIP Conference Proceedings, 2018, vol. 1955. doi: 10.1063/1.5033669.
- [42] Liu, Ran, et al. "Research on multi-motor synchronization control based on the ring coupling strategy for cutterhead driving system of shield machines." Applied Mechanics and Materials 52 (2011): 65-72.
- [43] Shi, Tingna, et al. "Improved relative coupling control structure for multi-motor speed synchronous driving system." IET Electric Power Applications 10.6 (2016): 451-457.
- [44] Zhao, D. Z., C. W. Li, and Jun Ren. "Speed synchronisation of multiple induction motors with adjacent cross-coupling control." IET control theory & applications 4.1 (2010): 119-128.
- [45] Zhu, Wenwu, et al. "Position control for permanent magnet synchronous motor based on neural network and terminal sliding mode control." Transactions of the Institute of Measurement and Control 42.9 (2020): 1632-1640.

[46] S. J. Rind, Y. Ren, Y. Hu, J. Wang, and L. Jiang, "Configurations and control of traction motors for electric vehicles: A review," *Chinese Journal of Electrical Engineering*, vol. 3, no. 3. 2017. doi: 10.23919/CJEE.2017.8250419.

[47] Vas, P. (1993). *Electrical Machines and Drives: A Space-Vector Theory Approach* (Monographs in Electrical and Electronic Engineering, 25) (1st ed.). Clarendon Press.

[48] Mohan, N. (2012b). *Electric Machines and Drives*. Wiley.

[49] Vas, P. (1993). *Electrical Machines and Drives: A Space-Vector Theory Approach* (Monographs in Electrical and Electronic Engineering, 25) (1st ed.). Clarendon Press.

[50] A. Bounab, A. Chaiba, and S. Belkacem, "Evaluation of the High Performance Indirect Field Oriented Controlled Dual Induction Motor Drive Fed by a Single Inverter using Type-2 Fuzzy Logic Control," *Engineering, Technology & Applied Science Research*, vol. 10, no. 5, 2020, doi: 10.48084/etasr.3799.

[51] Lazi, Jurifa Mat, et al. "Speed and Position Estimator of Dual-PMSM for Independent Control Drives using Five-Leg Inverter." *International Journal of Power Electronics and Drive Systems (IJPEDS)* 8.2 (2017).

[52] M. Jones, S. N. Vukosavic, D. Dujic, E. Levi, and P. Wright, "Five-leg inverter PWM technique for reduced switch count two-motor constant power applications," *IET Electr Power Appl*, vol. 2, no. 5, 2008, doi: 10.1049/iet-epa:20070497.

[53] W. Wang, J. Zhang, M. Cheng, and R. Cao, "Direct torque control of five-leg dual-PMSM drive systems for fault-tolerant purposes," *Journal of Power Electronics*, vol. 17, no. 1, 2017, doi: 10.6113/JPE.2017.17.1.161.

[54] W. Wang, J. Zhang, and M. Cheng, "A Dual-Level Hysteresis Current Control for One Five-Leg VSI to Control Two PMSMs," *IEEE Trans Power Electron*, vol. 32, no. 1, 2017, doi: 10.1109/TPEL.2016.2535294.