



## Robust control of active suspension system for a quarter rail car model using neural network based controller

Seyede Zohre Ahmadi SheykhShabani<sup>1</sup>, Seyed Mohammad Mousavi Gazafroodi<sup>2\*</sup>

<sup>1</sup>Masters student, Control Engineering, Iran University of Science and Technology

<sup>2</sup>Associate professor, School of Railway, Iran University of Science and Technology

### ARTICLE INFO

#### Article history:

Received: 10.08.2023

Accepted: 20.12.2023

Published: 26.12.2023

#### Keywords:

control vibration of rail car

active suspension

neural network

neural controller

robust controller

### ABSTRACT

Active suspensions that combine conventional mechanical structures with advanced electronics, sensors, and controllers have enabled the development of railway vehicles that can meet the new demands for higher speed, improved ride comfort, and stricter safety standards. Nevertheless, these aspects are affected by low track quality or high train speed. Therefore, it is crucial to regulate the vibration of the vehicle's suspension by using advanced control and automation techniques that can optimize the performance of a rail car suspension system. A method to improve these factors under such operating conditions is active suspension control. Active suspension enables designers to achieve a comfort level that is impossible with passive suspension elements. This work introduces the mathematical model of a two-degree-of-freedom system and the implementation of a robust artificial neural network control system for the active suspension system of a rail car. The control system that is proposed comprises a robust controller, a NARMA-L2 controller, which is a type of neural network controller that can be used to control nonlinear systems, and a model neural network of the rail car's suspension system. A standard PID controller is also used for comparison to control the railway vehicle's suspension system. The simulation results indicate that the proposed control system has enhanced efficiency and a better outcome at adjusting to random track disturbances for the railway vehicle's suspension.

## 1. Introduction

Dynamic impact loadings cause excessive vibrations in railway vehicles, which have a significant effect on the safety and stability of train operations. However, these vibrations are extremely hard to eliminate due to the complexity and diversity of railway lines and service environments [1]. The wheel-rail contact disturbances generate vibrations that travel through the primary suspension system to the bogie and then to the car body via the secondary

suspension system, resulting in discomfort for the passengers [2]. This also escalates the operating and maintenance costs, as well as diminishes the safety and performance of the system [3]. To enhance the vibration control, ride comfort, safety, and performance of railway vehicles, active suspension is a technology that employs actuators to exert forces or torques on the vehicle body or wheelsets. Active suspension systems can adjust to various operating conditions, track irregularities, and offer

\*Corresponding author

Email address: sm\_mousavi@iust.ac.ir

additional damping and stiffness to the vehicle suspension. Active suspension systems have been widely studied and applied in different forms, such as tilting trains, active secondary suspensions, and active primary suspensions. However, active suspension systems are subject to various challenges, such as system parameter and dynamic uncertainties, actuator nonlinearities and saturation, and track irregularities and external forces [4]. To cope with these challenges and ensure the stability and performance of the active suspension systems, robust and adaptive control methods are essential.

Over recent years, the suspension of railway vehicles has been developed in various forms due to its potential to improve ride comfort and vehicle maneuverability [5]. Suspension systems have been widely applied to modern automobiles and rail cars with complex control algorithms to reduce the effects of vertical acceleration caused by road disturbances [6]. Other purposes of suspension systems are to isolate sprung mass from the unsprung mass vibration, to provide directional stability during cornering, and to maneuver while providing damping for the high-frequency vibration-induced excitations [7]. Although the use of PID is common in industry, processes that dynamically involve a wide range of different behaviors, including suspension, limit the use of such a controller [8]. The electronically controlled active suspension system can potentially improve ride comfort as well as road handling and vehicle stability, especially for racing cars [9].

Swevers et al. have presented a flexible and transparent model-free control structure based on physical insights in the car, semi-active suspension dynamics used to linearize and decouple the system, and decentralized linear feedback [10]. However, recent advances in control and automation of control systems indicate significant improvement with the use of mechatronic applications and advanced controls such as PID-Fuzzy, fuzzy logic, etc. Fuzzy controllers, due to the lack of analytical tools such as stability analysis theory, control levels, or the same input-output relationships obtained by fuzzy inference systems, often face instability. Therefore, fuzzy systems are not usually used directly in control loops but rather

to adjust control parameters, such as gains in proportional-integral-derivative controllers. In addition, in these systems, the computational cost as well as the response time increase proportionally with the size of the inputs [11]. In adaptive methods, in order to limit the required estimates, the use of adaptive techniques usually requires modifications. This ensures accurate tracking as well as asymptotic tracking even in the absence of perturbation [12].

Yıldırım and Uzmay investigated the variation of vertical vibrations of vehicles using a neural network (NN) control system [13]. Without requiring an exact mathematical model of the system, neural network control can learn from data and adapt to uncertainties and nonlinearities, and it is one of the most promising methods for vibration control in railway vehicles' active suspension systems. The system's performance has improved recently by implementing and combining NN controllers with the previously mentioned controllers. Firstly, by investigating the conventional systems and using their data to train NN controllers, the conventional controllers were replaced by neural networks [14]. To estimate the damping forces needed under more abnormal conditions, such as damper aging and wear, NN controllers were also employed. In this strategy, the system response is measured and mapped to the actual state of the system parameters, and the NN controller assigns new modified adjustment signals to the MR damper [15].

Various types of NN control for active suspension vibration control of railway vehicles have been suggested by several studies, such as feed-forward NN [16], feedback NN [17], radial basis function NN [18], fuzzy NN [19], etc. However, the assumption of arbitrary accuracy in the NN approximation of the unknown system or controller, which may not correspond to the practical scenarios, is made by most of the existing literature on NN control. In addition, actuator saturation, which can harm system performance or stability [20], is often neglected in these studies.

Robust NN control methods that can tackle the NN approximation errors and actuator saturation have been developed by some researchers to address these challenges. For instance, a robust adaptive NN control method for active suspension systems of maglev trains, which used a back-stepping technique to design

a controller that could overcome the NN approximation errors and ensure the boundedness of the system states, was presented in [21]. They also added a sliding mode term to deal with the external disturbances. They demonstrated that their method can enhance the levitation gap stability and ride comfort compared to a conventional adaptive inversion controller. A saturated ARC method for active suspension systems of road vehicles, which used an anti-windup block to adjust the controller in case of actuator saturation and ensure the stability and performance preservation of the system, was introduced in [22]. They also used an adaptive law to update the controller parameters online. They demonstrated that their method can reduce body acceleration, body displacement, tire deflection, tire force, and actuator force compared to a passive suspension system.

Using an LMI approach, Saifi and Kumar [23] designed a controller that can reduce the H-infinity norm of the system output and improve the robustness against uncertainties and disturbances by proposing a H-infinity NN control method for active suspension systems of high-speed trains. Estimating the system states and parameters was done by them using an observer. A decrease in body acceleration, body displacement, suspension deflection, and actuator force compared to a passive suspension system was demonstrated by their method.

In this paper, a robust control system for vibration control of railway vehicles using NARMA-L2, based on a neural network for vibration control of railway vehicles, is proposed. The NARMA-L2 controller is a type of neural network controller that can be used to control nonlinear systems. The name NARMA-L2 stands for nonlinear autoregressive moving average with exogenous inputs and second-order learning. The idea behind this controller is to transform the nonlinear system dynamics into linear dynamics by canceling the nonlinearities. This can be achieved by using a neural network to approximate the system model and then using the inverse model to compute the control input. The paper first describes the rail car active suspension for the quarter rail car model under consideration. Second, the proposed control system and standard PID controller are outlined in Section 3. Third, the results of the proposed neural-based control system and PID control system are shown and discussed in Section 4.

Finally, the effectiveness of the proposed control method is concluded in Section 5.

## 2. Model of active suspension system

Supporting the rail car body, absorbing and storing energy, dissipating the vibration energy, and controlling the impulse from the rail that is transmitted to the car are the various goals of the suspension system of the railway vehicle, which is a complex mechanical system. Energy storage and damping components, namely springs and dampers, make up the suspension system. The rail car body is supported by the spring, and energy is absorbed and stored by it. The damper or shock absorber dissipates the vibration energy stored in the spring and controls the impulse from the rail that is transmitted to the body [22].

### 2.1. Quarter car model

The linear quarter rail car model is shown in Figure 1.

The bogie is represented by the sprung mass  $M_s$ , which is supported by two dampers and two springs. The dampers  $B_s$  and  $K_s$  model the suspension. The wheel mass and the wheelset contact with the rail are represented by the unsprung mass  $m_{us}$ , which is supported by two dampers and two springs, which are modeled by the damper bus and the stiffness  $K_{us}$ , respectively.

The system dynamics can be governed by the following equations that can be derived using Newton's laws [24]:

$$m_s \ddot{X}_s + k_s(X_s - X_{us}) + b_s(\dot{X}_s - \dot{X}_{us}) - F_c = 0 \quad [25] \quad (1)$$

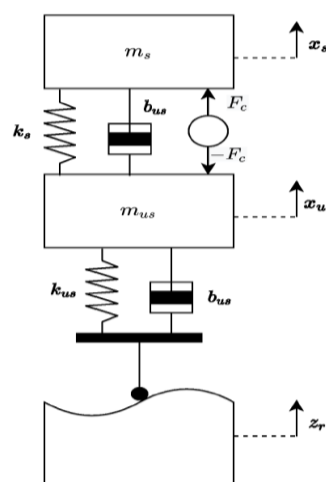

Figure 1. Quarter model.

$$m_u \ddot{X}_u + k_{us}(X_u - Z_r) - b_{us}(\dot{X}_{us} - \dot{Z}_r) + k_{us}(X_{us} - X_s) + C_s(\dot{X}_{us} - \dot{X}_s) + F_c = 0 \quad [25]$$

(2)

The bogie and the wheel have vertical displacements of  $X_s$  and  $X_{us}$ , respectively.  $Z_r$  is the input of the path disturbance and  $F_c$  is the hydraulic actuator force. Table 1 shows the nominal values used in this study.

Table 1. Quarter rail model design parameters.

Parameter	Value
$m_s$	5,333 kg
$m_u$	906.5 kg
$k_s$	430,000 N/m
$k_{us}$	2,440,000 N/m
$b_s$	20,000 Ns/m
$b_{us}$	40,000 Ns/m

The following state space shows the mathematical model of the active suspension:

$$\dot{x} = Ax + Bu + d \quad (3)$$

$$y = Cx + Du \quad (4)$$

where  $y$ ,  $u$ ,  $A$ ,  $B$ ,  $C$ , and  $D$  are the output vector, the input vector, the state matrix, the input matrix, the output matrix, and the feed-forward matrix, respectively.

$$\begin{bmatrix} \dot{x}_1 \\ \dot{x}_2 \\ \dot{x}_3 \\ \dot{x}_4 \end{bmatrix} = \begin{bmatrix} 0 & 1 & 0 & -1 \\ -\frac{K_s}{M_s} & \frac{B_s}{M_s} & 0 & \frac{B_s}{M_s} \\ 0 & 0 & 0 & 1 \\ \frac{K_s}{M_{us}} & \frac{B_s}{M_{us}} & -\frac{K_{us}}{M_{us}} & -\frac{B_s + B_{us}}{M_{us}} \end{bmatrix} \begin{bmatrix} X_1 \\ X_2 \\ X_3 \\ X_4 \end{bmatrix} + \begin{bmatrix} 0 \\ 0 \\ -1 \\ \frac{B_s}{M_{us}} \end{bmatrix} \begin{bmatrix} \dot{Z}_r \\ F_c \end{bmatrix} \quad [24]$$

$$\begin{bmatrix} y_1 \\ y_2 \end{bmatrix} = \begin{bmatrix} 1 & 0 & 0 & 0 \\ -\frac{K_s}{M_s} & -\frac{B_s}{M_s} & 0 & \frac{B_s}{M_s} \end{bmatrix} \begin{bmatrix} X_1 \\ X_2 \\ X_3 \\ X_4 \end{bmatrix} + \begin{bmatrix} 0 \\ 0 \end{bmatrix} \begin{bmatrix} \dot{Z}_r \\ F_c \end{bmatrix} \quad [24]$$

## 2.2. Actuator model

A device that can create mechanical motion from electrical, hydraulic, or pneumatic energy is called an actuator. In a train suspension system, an actuator can modify the suspension's stiffness and damping, which improves the comfort and stability of the train. The actuator is positioned between the sprung and unsprung masses and generates a counterforce to improve the system's performance by reducing acceleration and suspension travel.

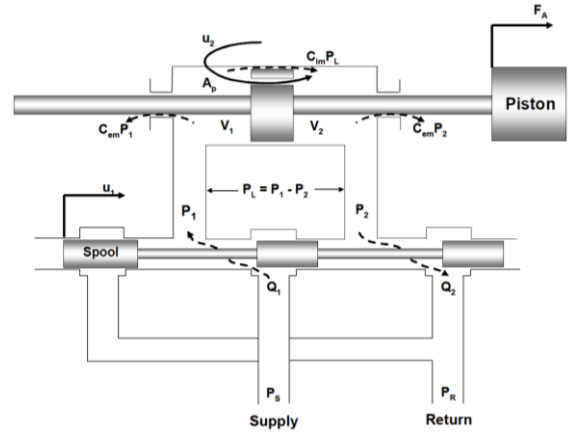

Figure 2. Physical schematic and variables for the hydraulic actuator [25].

An electrohydraulic system consists of an actuator, a primary power source, a spool valve, and a secondary bypass valve. As seen in Figure 2, the hydraulic actuator cylinder lies in a follower configuration with a critically centered electrohydraulic power spool valve with matched and symmetric orifices. Positioning of the spool  $u_1$  directs high-pressure fluid flow to either one of the cylinder chambers and connects the other chamber to the pump reservoir. This flow creates a pressure difference  $P_L$  across the piston. This pressure difference multiplied by the piston area  $A_p$  provides the active force  $F_a$  for the suspension system.

$$F_a = P_L \times A_p \quad [25] \quad (5)$$

The time constant of this first-class system is determined by experiment.

$$\dot{x}_v = \frac{1}{\tau} (-x_v + u) \quad [25] \quad (6)$$

In Equation (6),  $x_v$  is the position of the valve,  $\tau$  is the time constant of the system, and  $u$  is the electric current entering the valve.

The change in force is proportional to the position of the spool with respect to the center, the relative velocity of the piston, and the leakage through the piston seals. A second input  $u_2$  may be used to bypass the piston component by connecting the piston chambers. The dynamics for the hydraulic actuator valve are given below:

$$\dot{F}_a = A_p \alpha C_d \omega x_v \sqrt{\frac{P_s - \text{sgn}(x_v) P_L}{\rho}} - A_p \alpha C_{tm} P_L - A_p^2 \alpha (\dot{Z}_s - \dot{Z}_u) \quad [25] \quad (7)$$

In the above equation,  $P_s$  is the source pressure,  $A_p$  is the piston area,  $\omega$  is the width of the control valve, and  $\rho$  is the fluid density. Therefore, if the hydraulic actuator is considered a system, the input of this system will be  $u$ , and its output will be  $F_a$ .

### 3. Control systems

The developed NARMA-L2 control system and the PID controller are two different control structures that control the vibration of a quarter rail car model. The PID controller serves as a reference point to evaluate the effectiveness of the NARMA-L2 control system. The robust feedback controller is designed to ensure the stability and robustness of the system under uncertainties and disturbances, while the neural network predictive controller is used to improve the performance and adaptability of the system by learning from the data and predicting the future behavior of the system. The RNN control system can be applied to various nonlinear and complex systems, such as vehicle systems, robot manipulators, and chemical processes. The following two subsections of this section present the developed RNN control system and the PID controller. Figure 3 shows the operation of the

active suspension system and its interaction with various components that influence it.

#### 3.1. PID controller

Proportional  $P(e(t))$ , integral  $I(e(t))$  and derivative  $D(e(t))$  parts make up a PID controller. Assuming that each amplitude is completely decoupled and controlled independently from other amplitudes, the following equation gives the control input  $F(t)$ :

$$F(t) = K_P e(t) + K_I \int e(t) dt + K_D \frac{de(t)}{dt} \quad (8)$$

In this equation,  $e(t)$  is the control error

$$e(t) = x_d(t) - x_a(t) \quad (9)$$

where  $x_d(t)$  is the desired response, and  $x_a(t)$  is the actual response.  $K_p$  is called the proportional gain,  $K_I$  the integral gain, and  $K_D$  the derivative gain. The optimum PID gain parameters are determined by using the Zeigler-Nicholds methods.

#### 3.2. Robust neural network (RNN) control system

A robust feedback controller and a neural network predictive controller make up the proposed control system, which controls the vehicle system parameters. The following equation gives the law of the proposed controller systems:

$$F(t) = F_{FB}(t) + F_{NN}(t) \quad (10)$$

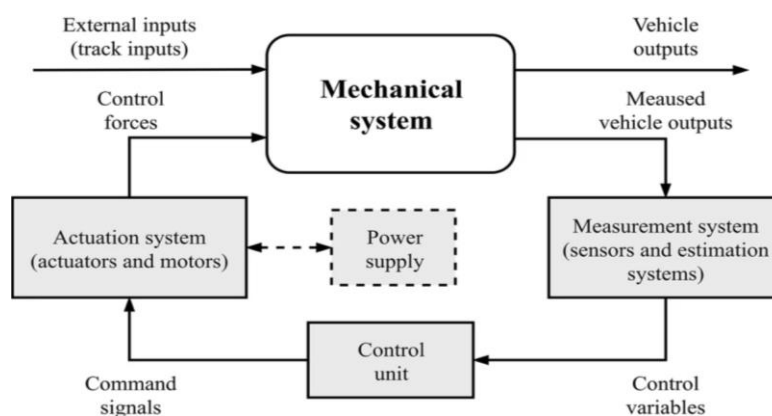

Figure 3. Workflow of an active suspension [26].

where  $F_{FB}$  is the robust feedback controller's force, and  $F_{NN}$  is the force of the neural network predictive controller.

### 3.2.1. Robust feedback controller

The robust feedback controller consists of a proportional, integral, and derivative (PID) term with an exponential function added to the derivative term. The exponential function helps reduce the control error by adjusting the controller gain according to time. A robust feedback controller can be applied to various systems, such as vehicle suspension systems, to improve ride comfort and road handling. A simple and effective control structure that is commonly used in industry is the PID controller. However, this structure cannot reduce the velocity control error well because it has fixed gain parameters. An exponential function is appended to the derivative component of the conventional PID controller. This function enables an exponential decrease of  $e(t)$ . A robust feedback controller architecture is proposed for this application. The following expression describes the first part of the control input for the robust feedback controller:

$$F_{FB}(t) = K_P e(t) + K_I \int e(t) dt + K_D \frac{de(t)}{dt} (K_R e^{(-K_{R1}t)}) \quad (11)$$

The gain matrices of the robust controller part are  $K_P$ ,  $K_D$ ,  $K_I$ ,  $K_R$  and  $K_{R1}$ . The parameters ( $K_R e^{(-K_{R1}t)}$ ) are used to control the vibration parameters of the vehicle's suspension for different road roughness. The ( $K_R e^{(-K_{R1}t)}$ ) parameters of a robust controller are obtained by using the method of trial and error. The parameters of the controller were set empirically after long training.

### 3.2.2. Feedback linearization control (NARMA-L2)

NARMA stands for nonlinear autoregressive moving average, which is a model that describes the relationship between the input and output of a system. L2 stands for linearization, which is a technique that transforms the nonlinear system dynamics into linear dynamics by canceling the nonlinearities. The NARMA-L2 controller can

perform better than conventional controllers, such as PID, for systems with complex and uncertain dynamics. NARMA-L2 control, or feedback linearization control [27], is the name of this controller. Narendra [28] derived this model. The feedback linear controller is the name of this controller when the process can be approximated by the same form; otherwise, the NARMA-L2 controller would be the name of this controller. The main concept of this controller is to transform nonlinear system dynamics into linear dynamics by canceling nonlinear factors.

## 4. Neural network control system

This section describes the mobile form of the system model and demonstrates the neural network's ability to identify this model. The method of using the identified neural network model as a controller will be explained later.

### 4.1. Identification of NARMA-L2 model

The system that requires control has to be identified before using feedback linearization or NARMA-L2 control. The system's forward dynamics have to be represented by a neural network that is trained for this purpose. Thus, the first step is to select a model structure. That is, the process model under investigation has to be extracted, and the neural network has to be trained to provide the system's forward dynamics. The following equation [29] shows the NARMA model.

$$y(k+d) = N[y(k), y(k-1), \dots, y(k-n+1), u(k), u(k-1), \dots, u(k-n+1)] \quad (12)$$

Equation (13) represents the input and output of the system by  $u(k)$  and  $y(k)$ . The desired data has to be used to train the neural network to approximate the nonlinear function  $N$  in the system identification phase. This step represents the identification process used in the predictive neural network controller. The ultimate goal is to make the system output follow the desired trajectory, or  $y(k+d) = y_r(k+d)$ , so the next

step is to design a nonlinear controller as follows:

$$u(k) = G[y(k), y(k - 1), \dots, y(k - n + 1), y_r(k + d), u(k - 1), \dots, u(k - m + 1)] \quad [28] \quad (13)$$

Using the above controller has the drawback that the control speed can be significantly impaired by using the backpropagation through time algorithm to train a neural network to approximate the function G and minimize the squared error. Narendra proposed a solution to this challenge, which is to use approximate models to represent the system. The controller used in this section is based on the approximate model NARMA-L2, which can be stated as follows:

$$\hat{y}(k + d) = f[y(k), y(k - 1), \dots, y(k - n + 1), u(k - 1), \dots, u(k - m + 1)] + g[y(k), y(k - 1), \dots, y(k - n + 1), u(k - 1), \dots, u(k - m + 1)]. u(k) \quad [28] \quad (14)$$

The above model represents the companion form of the system, in which the next control input u is absent from the system's nonlinear part. The companion form has the merit that the control signal can be determined such that the following consequence is accomplished:

$$y(k + d) = y_r(k + d) \quad (15)$$

The resulting controller will have the following form:

$$u(k) = \frac{y_r(k+d) - f[y(k), y(k-1), \dots, y(k-n+1), u(k-1), \dots, u(k-n+1)]}{g[y(k), y(k-1), \dots, y(k-n+1), u(k-1), \dots, u(k-n+1)]} \quad [29] \quad (16)$$

The direct use of the above equation can lead to challenges in the controller's feasibility because the above form requires the control input  $u(k)$  at the current moment to depend on the output  $y(k)$  at the current moment. The mentioned difficulty can be overcome by using the following equation:

$$y(k + d) = f[y(k), y(k - 1), \dots, y(k - n + 1), u(k), u(k - 1), \dots, u(k - n + 1)] + g[y(k), y(k - 1), \dots, y(k - n + 1), u(k - 1), \dots, u(k - n + 1)]. u(k + 1) \quad [29] \quad (17)$$

In the above equation,  $d \geq 2$ .

The structure of NARMA-L2 is shown in Figure 4.

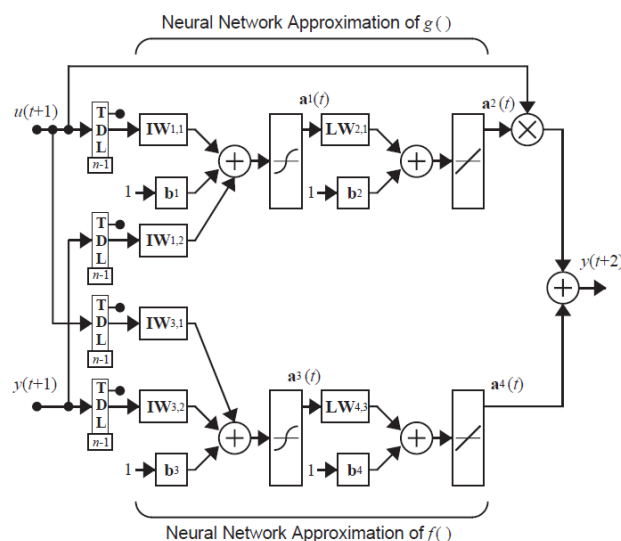

Figure 4. Neural network structure.

#### 4.2. Robust feedback controller

Using the NARMA-L2 model, the controller can be obtained as follows:

$$u(k + 1) = \frac{y_r(k+d) - f[y(k), y(k-1), \dots, y(k-n+1), u(k), \dots, u(k-n+1)]}{g[y(k), y(k-1), \dots, y(k-n+1), u(k), \dots, u(k-n+1)]} \quad [29] \quad (18)$$

The above equation is achievable for  $d \geq 2$ .

The block diagram of the NARMA-L2 controller is shown in Figure 5.

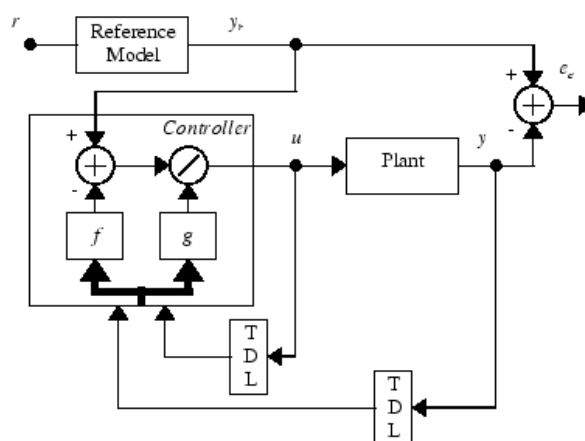

Figure 5. Active suspension control structure by feedback linearization controller.

The following block diagram shows how the controller can be implemented using the

NARMA-L2 process model that was identified in the previous step.

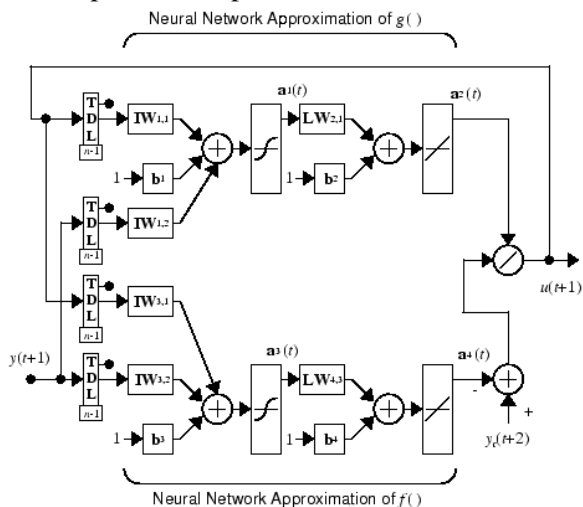

Figure 6. NARMA-L2 process model identified in the previous step.

### 5. Simulation results and discussion

This section compares the simulation results for the mentioned modes of the active suspension system.

#### 5.1. Active suspension without the use of a controller

The active suspension without a controller is depicted in the block diagram in Figure 7.

The response of the  $X_s - X_{us}$  function of the rail car’s active suspension system for a random track profile without any controller is illustrated in Figure 8. The uncontrolled response does not follow the desired random track profile, as Figure 8 indicates, due to the absence of any controller.

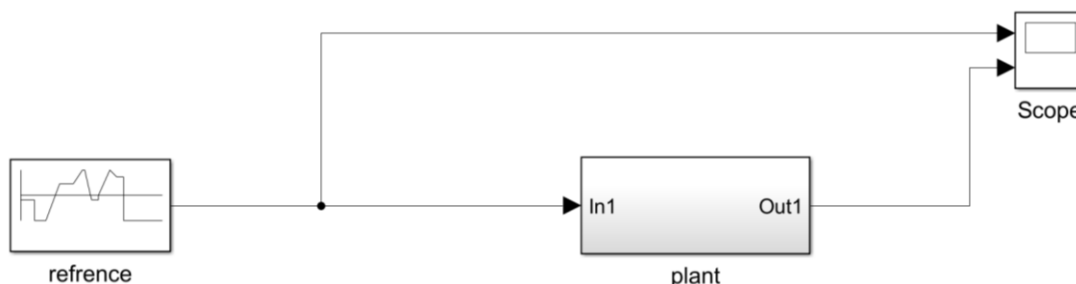

Figure 7. Block diagram of the suspension system without a controller.

The response of the vehicle's active suspension system to the random track roughness profile without any controller is shown by the simulation results of the vehicle's active suspension system without any controller, which demonstrate that the output does not precisely track the input when there is no controller to control the response, as the random changes in the path affect the error rate.

Thus, a controller is necessary to achieve optimal tracking. In this study, two types of PID controllers and a NARMA-L2 controller are used. Their responses are compared to assess their relative performance.

#### 5.2. Control of active vehicle suspension using PID controller

Using the PID controller, the performance of the system in the mode that was discussed in the previous section is investigated in this section. The block diagram of the active suspension system that uses the PID controller is shown in Figure 9.

Figure 10 shows the simulation result of active suspension control using the PID control system for a random track roughness profile. The simulation result indicates that the response still cannot completely track the rail and track roughness, but it has much better performance than before when no controller was used.



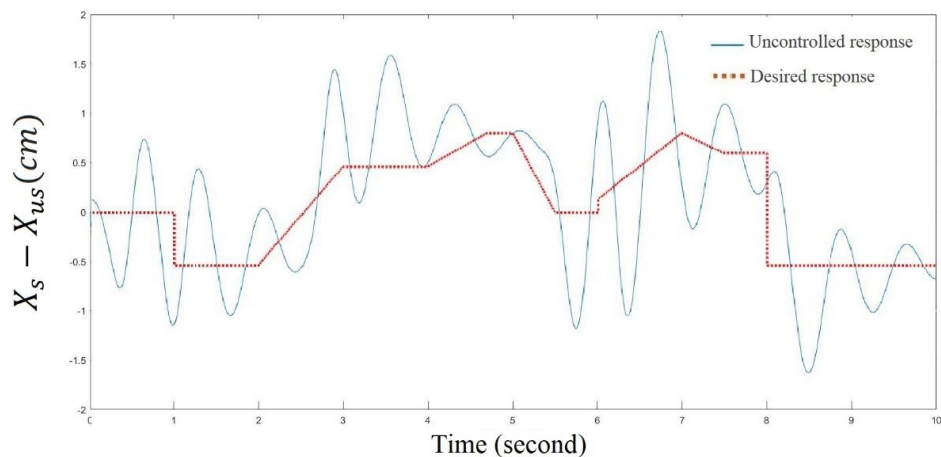

Figure 8. Uncontrolled response of  $X_s - X_{us}$

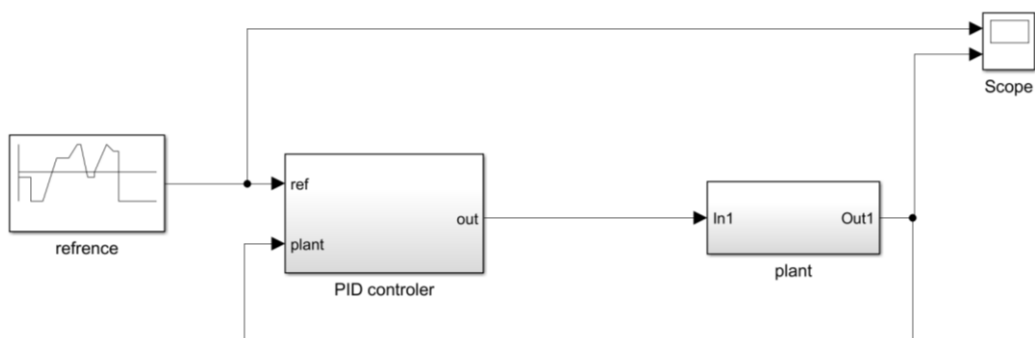

Figure 9. Block diagram of the suspension system using a PID controller.

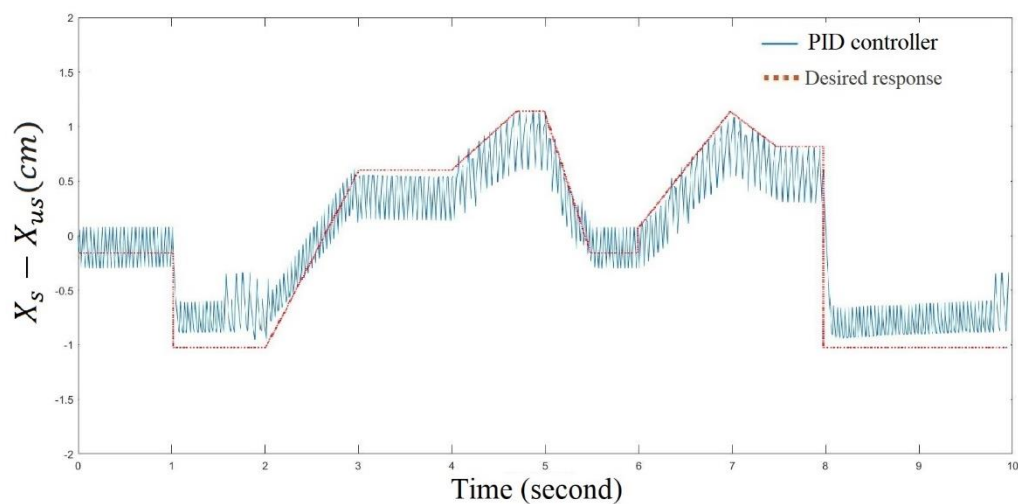

Figure 10. Controlled response of  $X_s - X_{us}$  function using a PID controller.

**5-3-Control of active vehicle suspension system using robust neural network (RNN) controller**

Using a robust neural network controller, the desired process for the mode that was described in the previous section is simulated, and each of their responses is examined. The rail car’s suspension system that uses the NARMA-L2 control system is illustrated in the block diagram in Figure 11.

The simulation results of the robust neural network control system for active suspension control against random road roughness

characteristics are displayed in Figure 12. The simulation result reveals that the response is very favorable, and the proposed controller has been able to predict the rail roughness well.

The control force applied by the neural network-based controller is illustrated in Figure 13. The figure demonstrates that the controller has performed the control action well for the control parameters considered at appropriate times by applying the desired control force. Moreover, the force applied by this controller is within an acceptable range.

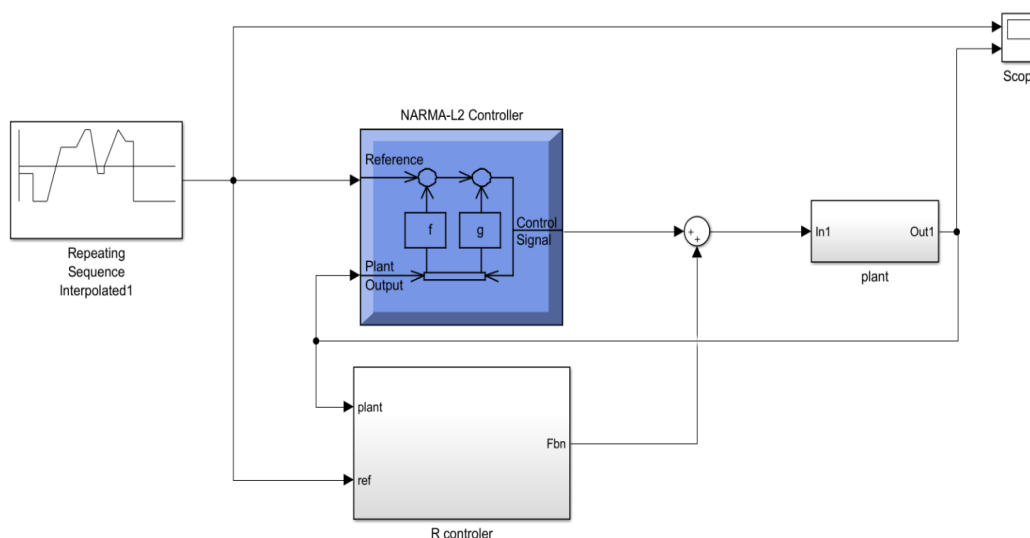

Figure 11. Block diagram of the suspension system using a robust neural network control system.

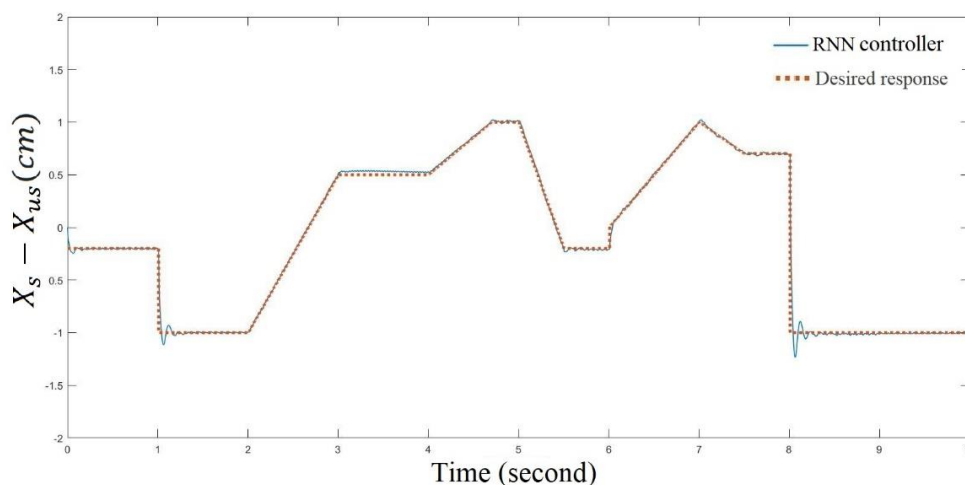

Figure 12. Controlled response of  $X_s - X_{us}$  function using a robust neural network control system.

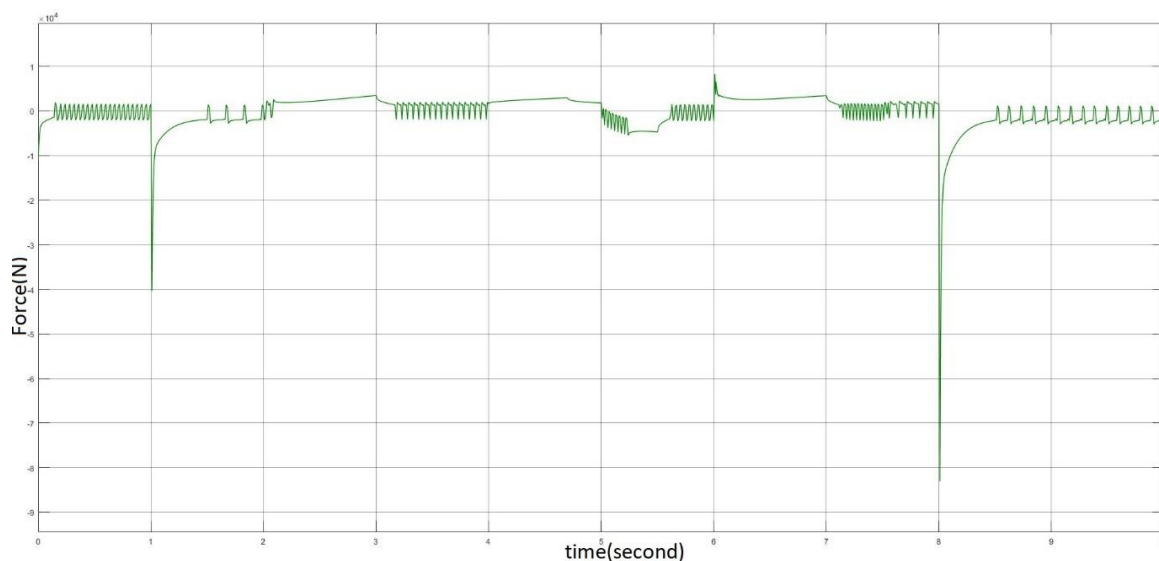

Figure13. Control force applied by a neural network-based controller.

## 6. Conclusion and discussion

This paper proposes a control system for a quarter of a rail car's active suspension system parameters using a neural network-based control system called NARMA-L2. The system is modeled as a two degrees-of-freedom system. The performance of the neural network-based control system is compared with that of the PID controller for the random road roughness profile. The simulation results demonstrate that the NARMA-L2 control system with a robust feedback controller can achieve high absolute road profile tracking performance for random road roughness. This confirms the effectiveness and robustness of the proposed neural network-based control system.

The standard PID controller is inferior to the RNN control system. This is because it has several drawbacks compared to other methods. It has robust performance, meaning that it can manage both linear and non-linear dynamics of the system by using an exponential function in the robust controller that reduces the error  $e(t)$  exponentially. It also has self-organization, meaning that it can create its own representation of the information it receives during the learning time and improve the

control strategy. It has error tolerance, meaning that it can cope with faults in the system by distributing them in the parallel structure of the neural network and maintaining a good level of performance.

## References

- [1] Jing, L., Wang, K., & Zhai, W. (2021). Impact vibration behavior of railway vehicles: a state-of-the-art overview. *Acta Mechanica Sinica*, 1-29.
- [2] Sharma, S. K., & Kumar, A. (2017). Ride performance of a high speed rail vehicle using controlled semi active suspension system. *Smart Materials and Structures*, 26(5), 055026.
- [3] Shin, D., Lee, G., Yi, K., & Noh, K. (2016). Motorized vehicle active suspension damper control with dynamic friction and actuator delay compensation for a better ride quality. *Proceedings of the Institution of Mechanical Engineers, Part D: Journal of Automobile Engineering*, 230(8), 1074-1089.
- [4] Ghaffari, V., Mobayen, S., Din, S. U., Bartoszewicz, A., & Jahromi, A. T. (2021). A robust  $H_\infty$  fault tolerant controller for uncertain systems described by linear fractional transformation model. *IEEE Access*, 9, 104749-104760.
- [5]. Cao D, Song X, Ahmadian M. Editors' perspectives: road vehicle suspension design, dynamics, and control. *Vehicle Syst Dyn* 2011;49(1-2):3-28.
- [6] Ulum, Z., Affaf, M., & Suparwanto, A. (2017, August). Active suspension systems design of a light rail vehicle using MPC with preview information disturbance. In *2017 5th International Conference on Instrumentation, Control, and Automation (ICA)* (pp. 18-23). IEEE.
- [7] Senthil Kumar, P., Sivakumar, K., Kanagarajan, R., & Kuberan, S. (2018). Adaptive neuro fuzzy inference system control of active suspension system with actuator dynamics. *Journal of Vibroengineering*, 20(1), 541-549.
- [8] Choi HD, Ahn CK, Lim MT, Song MK. Dynamic output-feedback  $H_\infty$  control for active half-vehicle suspension systems with time-varying input delay. *International Journal of Control, Automation and Systems*. 2016 Feb 1;14(1):59-68.
- [9] Oh, J. S., Shin, Y. J., Koo, H. W., Kim, H. C., Park, J., & Choi, S. B. (2016). Vibration control of a semi-active railway vehicle suspension with magneto-rheological dampers. *Advances in Mechanical Engineering*, 8(4), 1687814016643638.
- [10]. J. Swevers, C. Lauwerys, B. Vandersmissen, M. Maes, K. Reybrouck, P. Sas, A model-free control structure for the on-line tuning of the semi-active suspension of a passenger car, *Mechanical Systems and Signal Processing* 21 (2007) 1422–1436.
- [11] Li H, Jing X, Lam HK, Shi P. Fuzzy sampled-data control for uncertain vehicle suspension systems. *IEEE transactions on cybernetics*. 2013 Sep 10;44(7):1111-26.
- [12] Chantranuwathana S, Peng H. Adaptive robust force control for vehicle active suspensions. *International Journal of Adaptive Control and Signal Processing*. 2004 Mar;18(2):83-102.
- [13] S. Yildirim, I. Uzmay, Neural network applications to vehicle's vibration analysis, *Mechanism and Machine Theory* 38 (2003) 27–41.
- [14] Gandhi, P., Adarsh, S., & Ramachandran, K. I. (2017). Performance analysis of half car suspension model with 4 DOF using PID, LQR, FUZZY and ANFIS controllers. *Procedia Computer Science*, 115, 2-13.
- [15] Savaresi, D., Favalli, F., Formentin, S., & Savaresi, S. M. (2019). On-line damping estimation in road vehicle semi-active suspension systems. *IFAC-PapersOnLine*, 52(5), 679-684.
- [16] Kalaivani, R., Sudhagar, K., & Lakshmi, P. (2016). Neural network based vibration control for vehicle active suspension system. *Indian Journal of Science and Technology*, 9(1), 1-8.
- [17] Dridi, I., Hamza, A., & Ben Yahia, N. (2023). Control of an active suspension system based on long short-term memory (LSTM) learning. *Advances in Mechanical Engineering*, 15(2), 16878132231156789.
- [18] Chen, C., Xu, J., Rong, L., Ji, W., Lin, G., & Sun, Y. (2022). Neural-network-state-observation-based adaptive inversion control method of maglev train. *IEEE Transactions on Vehicular Technology*, 71(4), 3660-3669.

- [19] Pang, H., Liu, F., & Xu, Z. (2018). Variable universe fuzzy control for vehicle semi-active suspension system with MR damper combining fuzzy neural network and particle swarm optimization. *Neurocomputing*, 306, 130-140.
- [20] Sun, W., Zhao, Z., & Gao, H. (2012). Saturated adaptive robust control for active suspension systems. *IEEE Transactions on Industrial Electronics*, 60(9), 3889-3896.
- [21] Wai, R. J., & Lee, J. D. (2008). Adaptive fuzzy-neural-network control for maglev transportation system. *IEEE Transactions on Neural Networks*, 19(1), 54-70.
- [22] Liu, Y., & Li, W. (2020). Adaptive output feedback control for the trajectory tracking of high-speed trains with disturbance uncertainties on the basis of neural network observers. *Journal of advanced transportation*, 2020, 1-16.
- [23] Saifi, D., & Kumar, P. (2022, March). Robust Control Design of Active Suspension System for Quarter Car with Neural Network and Ziegler–Nichols Tuning Method. In *Advances in Mechanical Engineering and Technology: Proceedings of 6th International Conference on Advanced Production and Industrial Engineering (ICAPIE)-2021* (pp. 397-406). Singapore: Springer Singapore.
- [24] Wéber, A., & Kuczmann, M. (2019). State Feedback Controller Design of an Active Suspension System for Vehicles Using Pole Placement Technique. *Acta Technica Jaurinensis*, 12(3), 178-190.
- [25] Kis, K. Á., Korsoveczki, G., Sarvajcz, K., Korondi, P., Kocsis, I., & Balajti, I. (2023, September). Quarter Car Suspension State Space Model and Full State Feedback Control for Real-Time Processing. In *2023 Signal Processing Symposium (SPSymposium)* (pp. 73-78). IEEE.
- [26] Fu, B., Giossi, R. L., Persson, R., Stichel, S., Bruni, S., & Goodall, R. (2020). Active suspension in railway vehicles: a literature survey. *Railway Engineering Science*, 28, 3-35.
- [27] Levin, A. U., & Narendra, K. S. (1996). Control of nonlinear dynamical systems using neural networks. II. Observability, identification, and control. *IEEE transactions on neural networks*, 7(1), 30-42.
- [28] Narendra, K. S. (1989). *Annaswamy. Stable adaptive systems. Information And System Sciences. Prentice-Hall.*
- [29] Uçak, K., & Günel, G. Ö. (2021). Online support vector regression based adaptive NARMA-L2 controller for nonlinear systems. *Neural Processing Letters*, 53(1), 405-428.